

ELGE TECHNOLOGIES

13 Central Drive, Glen Head, NY 11545

Tel: 516-945-9392

E-Mail: elgeh@gmail.com

SUBMITTAL

PROJECT: Ruppert Housing

Elge Technologies factory packaged domestic hot water heating system consisting of the following:

MANUFACTURER	PRODUCT	QUANTITY	DESCRIPTION
ELGE	A-81	8	ELGE 90 gpm Heat Exchanger Steam 5-10psi / Water 40 -140 temperature rise
ELGE	Jacket	8	2" Fiberglass insulation; Steel Jacket.
ELGE	Base/Frame	8	Painted support frame
TRERICE	91400	8	Steam Control Valve - Self Operated with remote sensing bulb
WATTS	40L-2	8	T & P Safety Relief Valve
Mepco	Series 44	8	F & T Trap
Mepco	SSA	8	Strainer
CASH ACME	FWC	8	RELIEF VALVE
VENT RITE	57	8	STEAM VENT
Paxton	57	8	Hot Water Mixing Valve

ELGE®

Shell and Coil Heat Exchanger

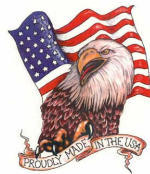

www.elge-technologies.com

ELGE®

Shell and Coil Heat Exchanger

High-Efficiency
HEAT EXCHANGERS

AS GREEN
AS IT GETS!

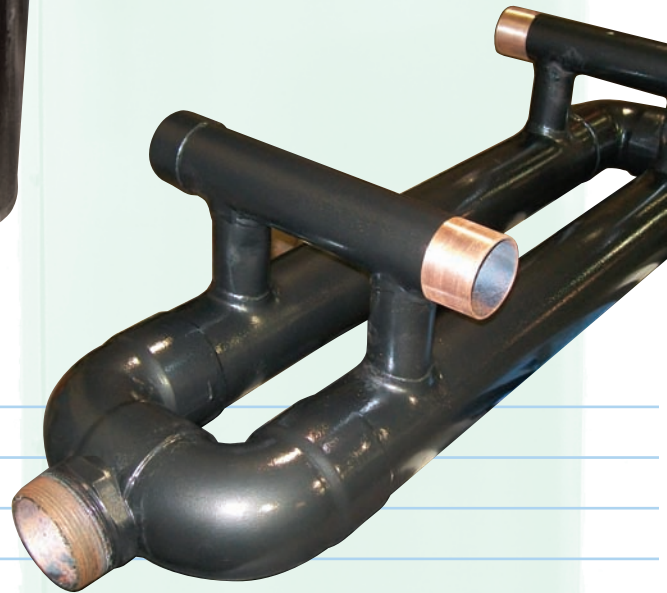
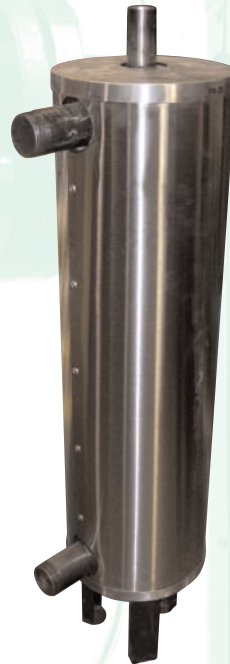

- Optimal Shell & Coil Design is built to Last!
Highest Efficiency Heat Transfer
- Fuel Saving, Space Saving
- Low Maintenance, Self-Cleaning
- Instantaneous Domestic Hot Water Heating
- Single Heat Exchangers & Complete Packaged Systems
- STEAM-to-WATER or WATER-TO-WATER Units

ELGE®

Shell and Coil Heat Exchanger

Reclaiming & Saving Energy Since the 1870's

ASME Certified

ELGE® is the World Leader in Shell & Coil Heat Exchanger Technology.

ELGE® Shell & Coil Heat Exchangers Type A and AR

General Description

At ELGE® we have constructed a series of heat exchangers with optimum designs to suit operating conditions inherent to subscriber stations in District Heating Systems and Central Heating Systems.

DESCRIPTION

ELGE® Shell & Coil Heat Exchangers are designed for different environments such as water-water and steam-water.

They are designed according to the counterflow principle for best thermal properties, at either full load or part load. The heating surface in ELGE® Shell and Coil Heat Exchangers is unique. The copper tubes are coiled in layers with a spacer element in between. The tubes are given an oval cross section when coiled. The collection chamber, where the copper tubes open out, comprises a specially designed collection chamber for optimum flow. The connecting ends of the copper tubes, which are connected to the collection chamber, are round - this is to provide low inlet and outlet velocities.

ELGE® Shell & Coil Heat Exchangers are very compact since the smooth copper tubes are spun around a small core. The small outside dimensions and the low total weight facilitate the handling of the heat exchangers.

ELGE® Shell & Coil Heat Exchangers have fiberglass insulation. This has a long life span and is not affected by for example, welding. The insulating material is covered with stainless steel jacket, a surface which is insensitive to impact and knocks. To provide extra strong protection against damage during transportation and installation, the insulation walls are made of thick sheet steel and are anchored to the pressure vessel. The insulation can be easily removed to provide access for inspection of the pressure vessel.

ELGE® Shell & Coil Heat Exchangers are easy to install and connect. The adjustable floor stand facilitates setting up and long pipe ends facilitate connection.

ELGE® Shell & Coil heat Exchangers type A and AR are manufactured according to the ASME Code. Quality Assurance Standard and has an optional ASME U-Stamp.

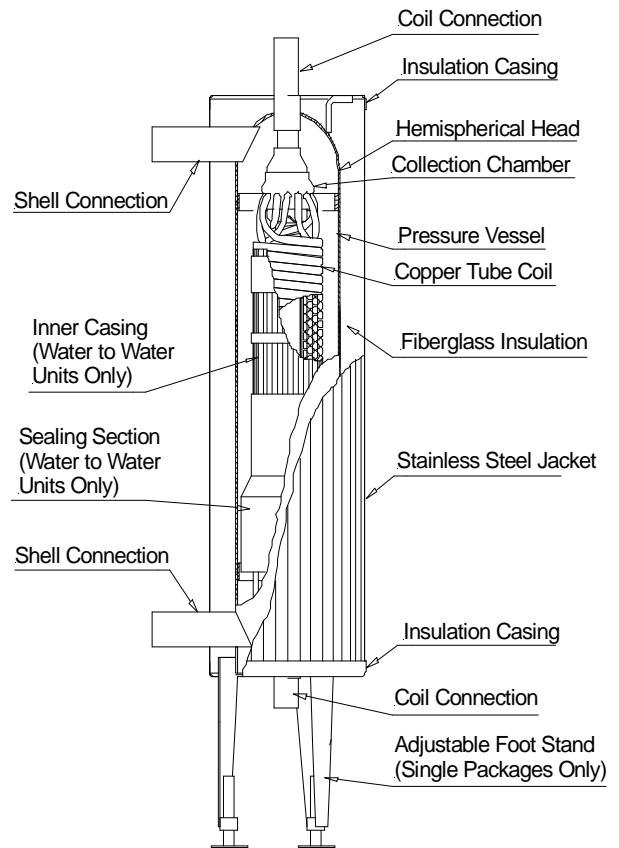

ELGE® Shell & Coil Heat Exchangers are available in a wide range of sizes. This range increases the potential for finding the optimum solution where oversizing is reduced to the minimum in terms of capacity and space requirements.



Shell and Coil Heat Exchanger

Heat Transfer Surface Area

ITEM#	DESCRIPTION	Surface area for heat transfer in ²
1	All Tubes + Chamber (External Surface)	20,965.22
2	Shell (Internal Surface)	2,614.15
3	Shell (External Surface)	2,873.86

Surface Area of Chamber and Tank

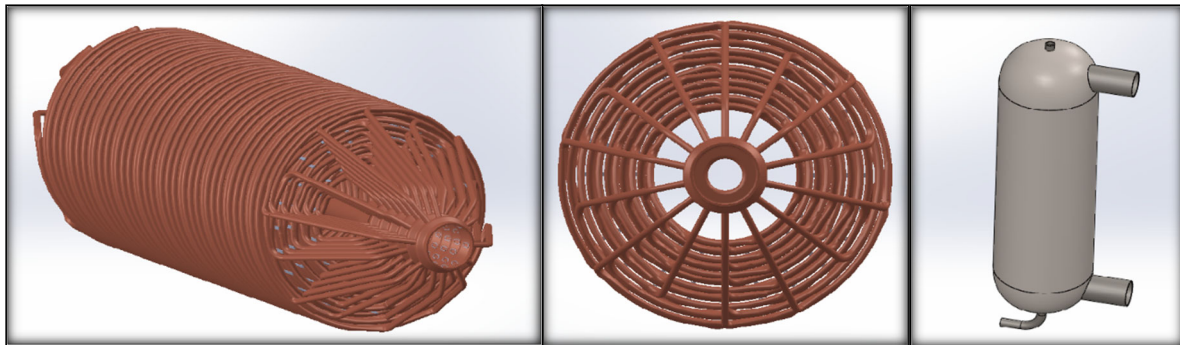

Outer surface of the Tubes:

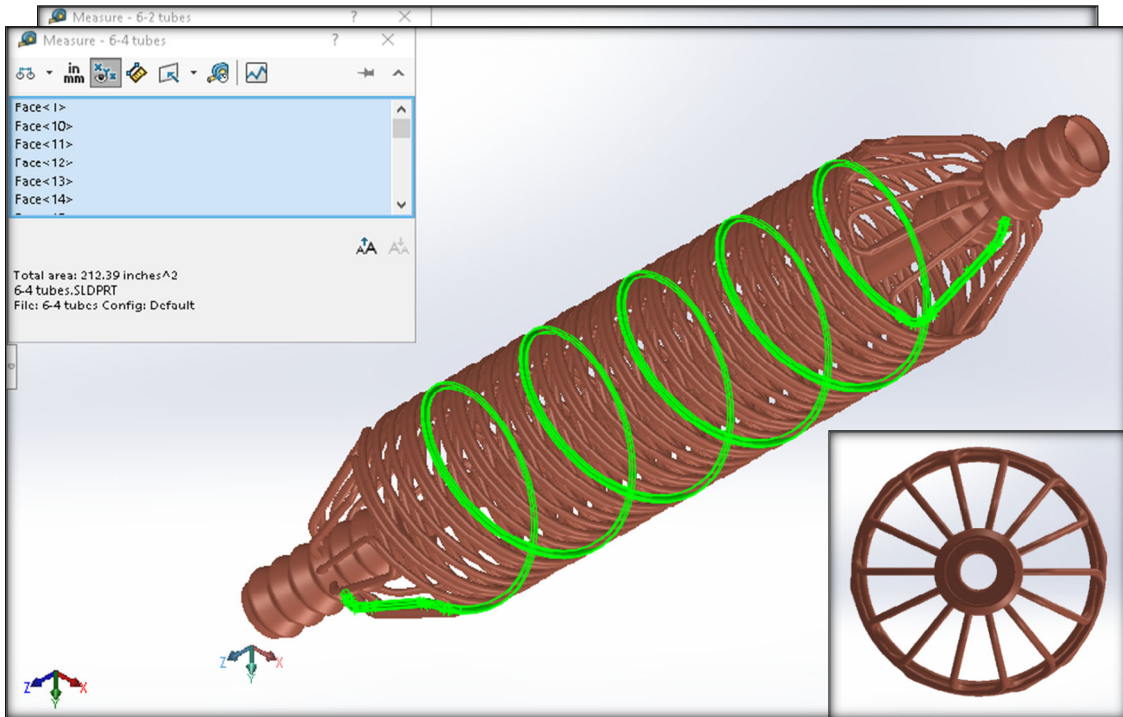
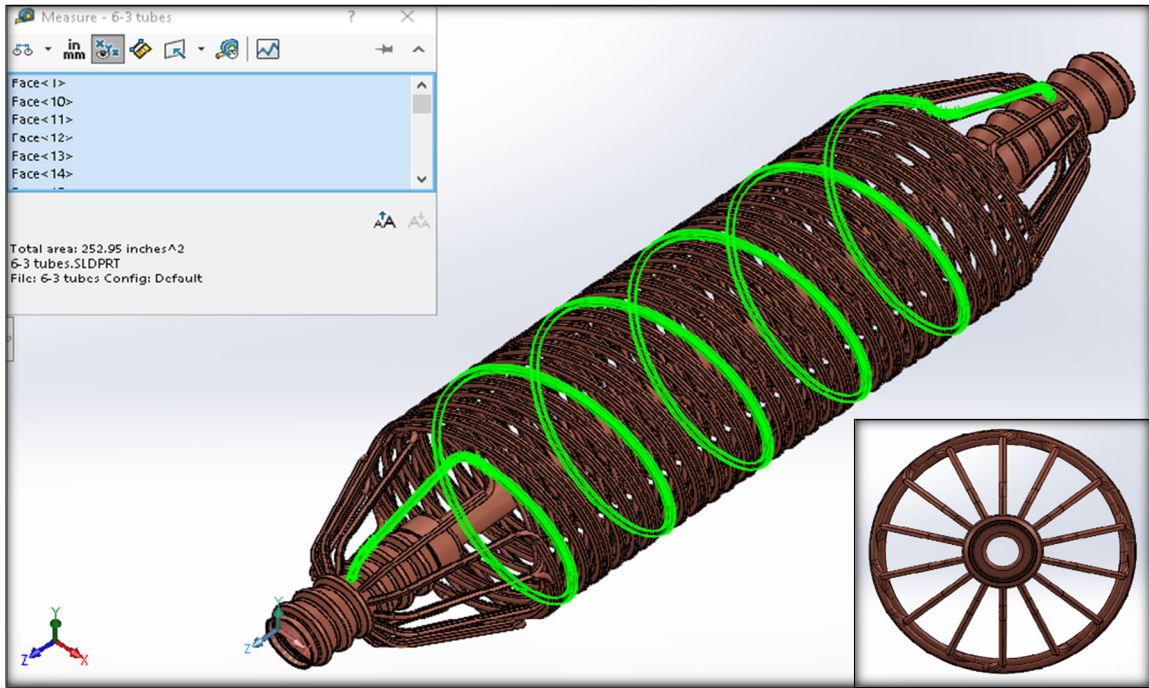

ELGE TECHNOLOGIES L.L.C.

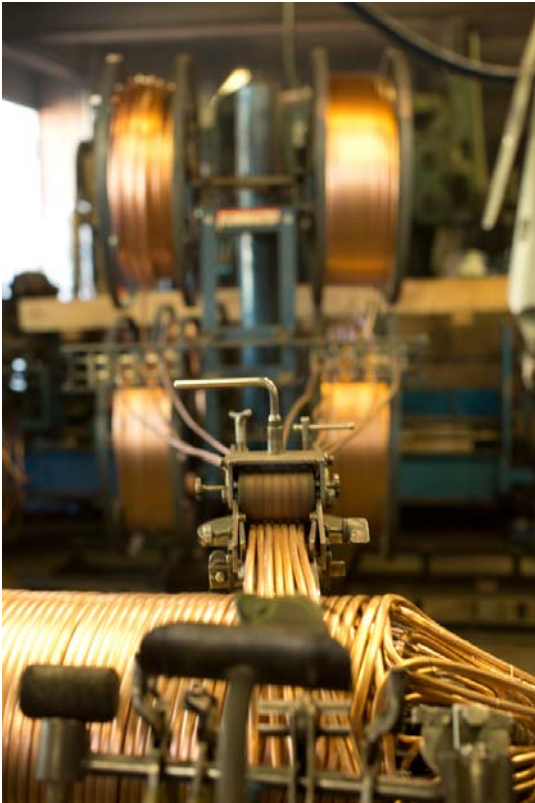

Coil Design is Reliable, Self-Cleaning

ELGE®'s coil design eliminates stress at the connection points due to expansion and contraction. In addition, this movement causes the coil to be self-cleaning. Scale is automatically removed and can be easily flushed from the system through the flush valve on the bottom of the Steam Water Heater.

Efficient and Economical

ELGE®'s Steam Water Heater is efficient in both space and performance. Its vertical design requires less than 4 square feet. ELGE's use of proven components provides a reliable yet economical package.

Eliminates Storage Tank Hazards

Expensive, space-hog storage tanks can be eliminated or their size minimized by using an instantaneous ELGE® Steam Water Heater. Storage tanks are a breeding ground for corrosion-causing bacteria and hazardous bacteria such as legionella, etc. Stratified tanks can supply the ideal breeding temperature for any type of water borne bacteria.

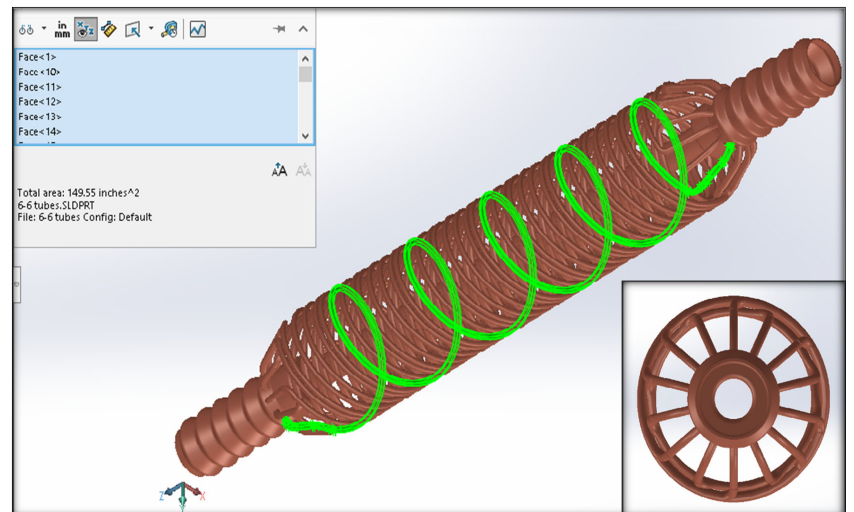
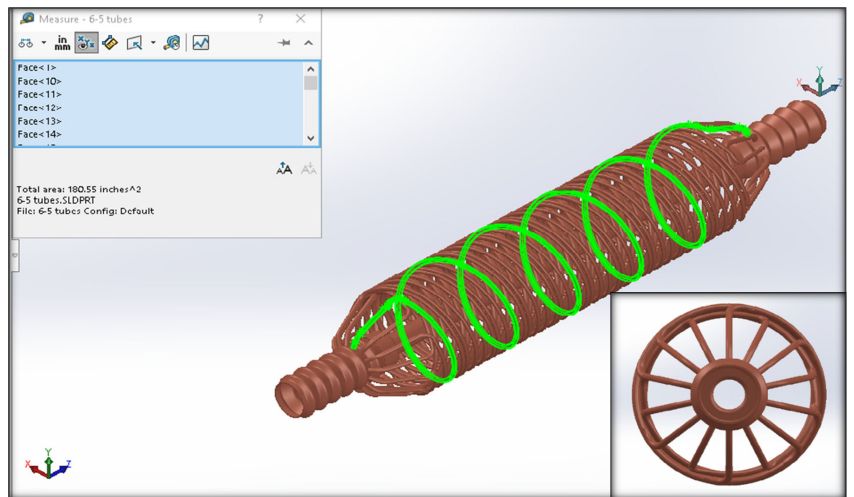

Shell and Coil Heat Exchanger

Type A Steam to Water Dimensions

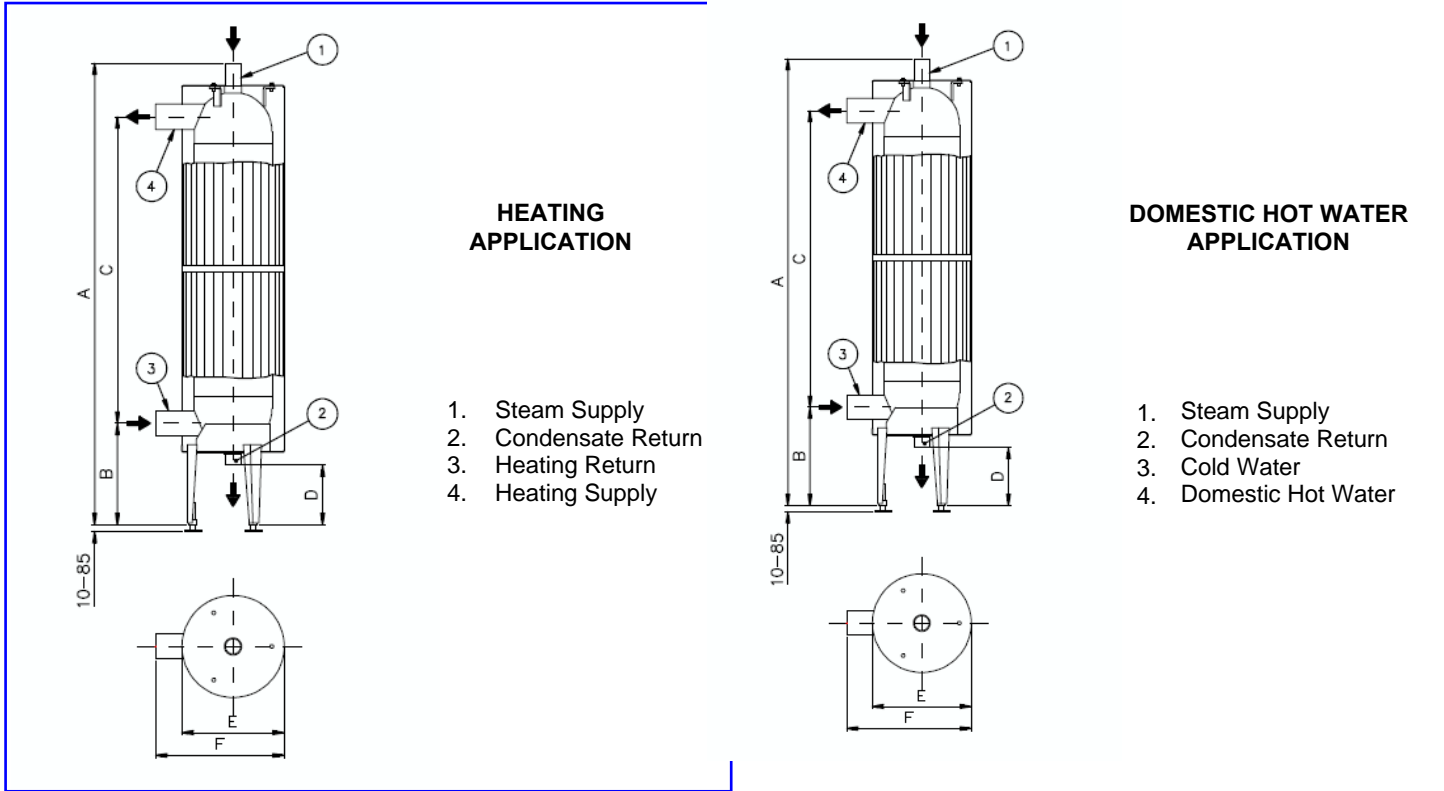

Type	A	B	C	D	E	F	Weight lb	Connections Heating		Connections DHW		Volume US Gal.	
								1	2	1	2	Shell	Coil
								inch	inch	inch	inch		
A-11/A-21	43.5	11.0	26.7	7.7	10.0	17.7	77/88	1 1/4	2	2	1 1/4	2.6/2.4	0.8/0.8
A-31/A-41	45.5	11.3	27.8	8.5	11.6	19.2	110/121	1 1/2	2 1/2	2 1/2	1 1/2	4.7/4.0	1.0/1.6
A-51/A-61	49.6	14.0	28.2	9.2	14.1	21.8	176/198	2	3	3	2	8.7/7.7	2.4/2.9
A-71/A-81	54.4	14.4	31.8	9.7	16.9	25.5	309/331	2 1/2	4	4	2 1/2	15.6/14.5	3.7/4.7

MODEL A Steam -Water Heater Piping

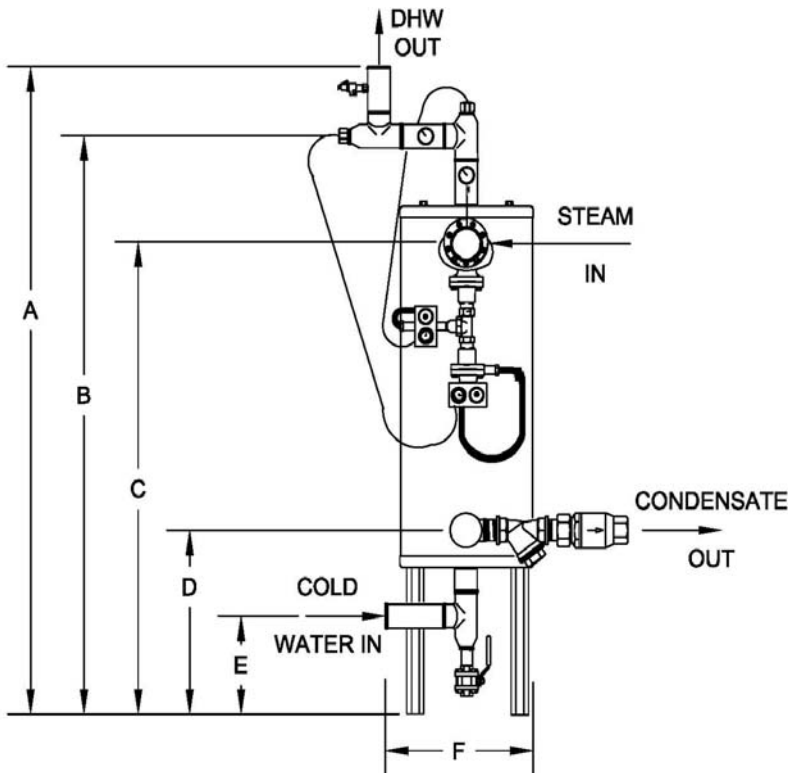

ELGE® Steam Water Heater Features

- Shell and Coil Water Heater-Insulated with Stainless steel jacket.
- Self-actuated Temperature Control Valve with Safety Temperature Limiter or Pneumatic Temperature Control Valve.
- Temperature Sensor.
- Float - Thermostatic Steam Trap.
- Temperature / Pressure Relief Valve.
- Y-strainer on condensate before trap.
- Temperature and pressure gauges.

NOTE: Self-actuated Temperature Control Valve with Safety Temperature Limiter shown at left.

Heat Exchanger Data Pressure and Temperature

Max. Operating Pressure 400 psig

Max. Operating Temperature 600° F

Materials of Construction

Pressure Vessel: Carbon Steel Consistent with ASME

Pressure Heads: Carbon Steel Hemispherical Heads

Copper Tube: 3/8" Copper Tubing with 22 gauge wall (formed into oval shape)

ELGE® SPU Model	Dimensions in inches						CW inlet	HW outlet	Weight pounds
	A	B	C	D	E	F			
A11	63	51	37.7	11*	2.5	10	1.25	1.25	220
A21	63	51	37.7	11*	2.5	10	1.25	1.25	230
A31	65	53	39.1	11.3*	2.3	11.6	1.50	1.50	260
A41	65	53	39.1	11.3*	2.3	11.6	1.50	1.50	270
A51	69	57	42.2	14*	4.8	14.1	2.00	2.00	325
A61	69	57	42.2	14*	4.8	14.1	2.00	2.00	355
A71	74	62	46.2	14.4*	4.2	16.9	2.50	2.50	470
A81	74	62	46.2	14.4"	4.2	16.9	2.00	2.00	490

NOTE: * For trap and strainer size see selection tables
 + For Valve size see tables
 + Dimensions may change without notice

YOUR GUARANTEE OF QUALITY

The heat exchanger and valve come with ELGE® 's standard one (1) year warranty. However, ELGE® offers an economical extended warranty **option** as follows:

The pressure vessel and coil shall be warranted unconditionally for five (5) years to be free from defects in material and workmanship, and against failure due to thermal shock or mechanical failure. This warranty shall be non-prorated and shall expire five (5) years from date of shipment. It shall be extended by ELGE® to the end user. See ELGE® Manual for details.



Elge Flow Through Shell & Coil HX Design

Even, Controlled Flow:

When the copper is coiled, it is molded to a oval shape to yield a larger heat transfer area and spacers are inserted between the rows. Hot water or steam enters the head and is diverted through the coil bundle in a counter/cross-flow manner. The inner casing insure even and controlled flow over the exterior of the tubes in the bundle.

Self – Cleaning:

The ability of the coil to flex with temperature changers combined with the increased flow rate through the oval coil section insures a minimum of deposits.

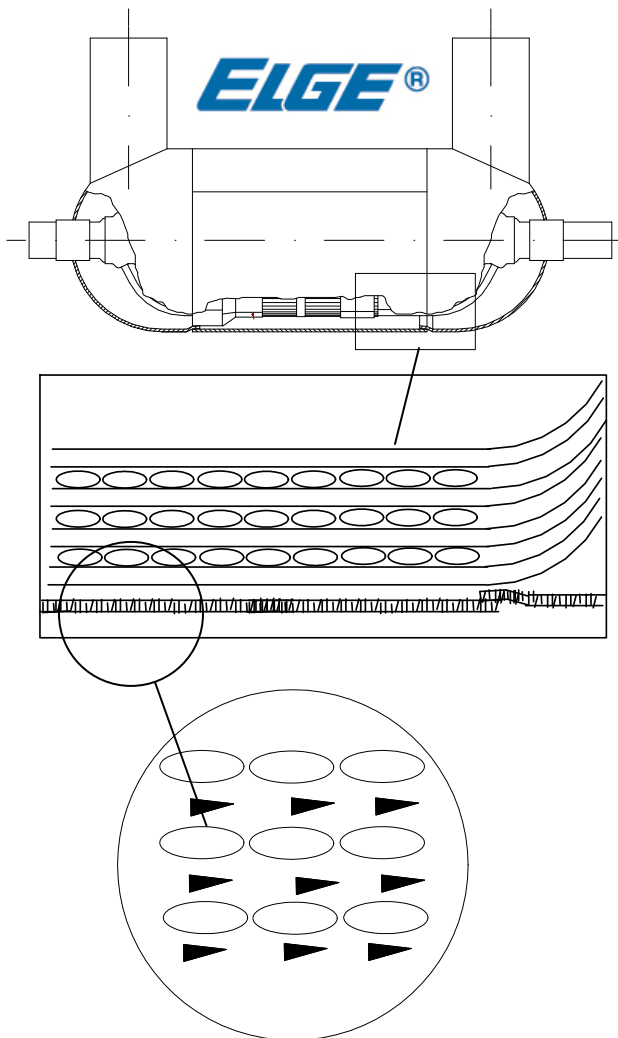

Efficient Flow Where Needed:

The design of the collection chamber, and the angle of the tubes results in a low flow rate and less resistance where the water enters the tube. This means less erosion. However, as the tube changes from round to oval, there is a 50% increase in flow rate at the point of heat exchange.

Designed to Last

The connection of the tubes to the chamber and of the coil to the head provide a large, strong silver solder area (15% silver used Cu-Cu and 45% used Cu-Steel). The coil design allows expansion and contraction to occur in the coil and minimizes any stress at these connective points.

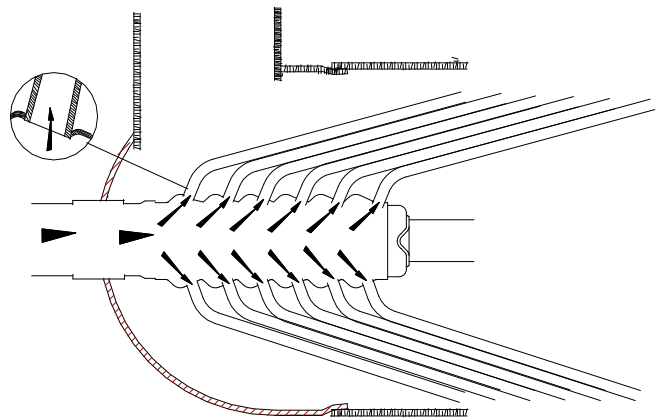

ELGE®

Shell and Coil Heat Exchanger

THIS DRAWING SHALL NOT BE COPIED, DISPOSED OF, NOR USED FOR ANY PURPOSE OTHER THAN THAT FOR WHICH IT IS FURNISHED, WITHOUT THE WRITTEN PERMISSION OF CMS HEAT TRANSFER DIVISION, INC.

CMS MODEL: A-81
ALL STEEL CONSTRUCTION

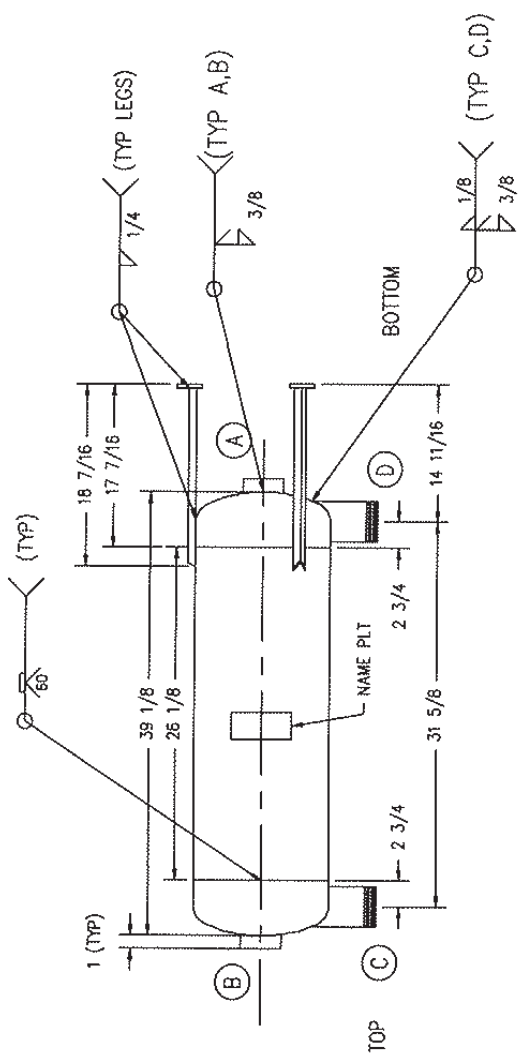

TOP VIEW

LEG BASE PLATE

	NPS / OD	SCH / THK		DESIGN CONDITIONS	SHELL SIDE
Nozzle A	3	160	SA-106 Gr B Sml Steel Pipe	DESIGN PRESSURE (psig)	325
Nozzle B	3	160	SA-106 Gr B Sml Steel Pipe	TEST PRESSURE (psig)	425
Nozzle C	4	XS	SA-106 Gr B Sml Steel Pipe MPT End (1.5" thread length)	DESIGN TEMPERATURE / MIN (°F)	400 / -20
Nozzle D	4	XS	SA-106 Gr B Sml Steel Pipe MPT End (1.5" thread length)	CAPACITY (Gal)	28
Shell Cylinder	14.0	0.375	SA-106 Gr C Sml Steel Pipe	CORROS ALLOW, C STL ONLY (in)	0.0625
Shell Cover	14.0	0.375	SA-234 WPB C Steel Weld Cap	RADIOGRAPHY	None
Legs			2 x 2 x 1/8 SA-36 Steel Angle w/ 3/8 SA-36 Base Plate	PWHT	None
				FLUID	WATER

CODE: ASME SECT VIII, DIV 1, 2017
WEIGHT: EMPTY 194 FLOODED 430 lb
DATE: 06-17-18 DRAWN: CM CHKD: MD APPD: CM



NO.	DATE	BY	REVISIONS	JOB NO.	DWG NO.	REV
					10.2876.00	

NOTES: ASME STAMP NATIONAL BOARD INSPECTION & REGISTRATION ARE REQUIRED
CRN FOR ONTARIO IS REQUIRED
IMPACT TEST NOT REQD PER SECT VIII, DIV I, PARA UCS-66
PAINT : ONE COAT KEM HI-TEMP HEAT FLEX II 450 (GREY)

91000 Series Temperature Regulator

The "Self-Op" (Self-Operated Temperature Regulator)

TEMPERATURE REGULATORS

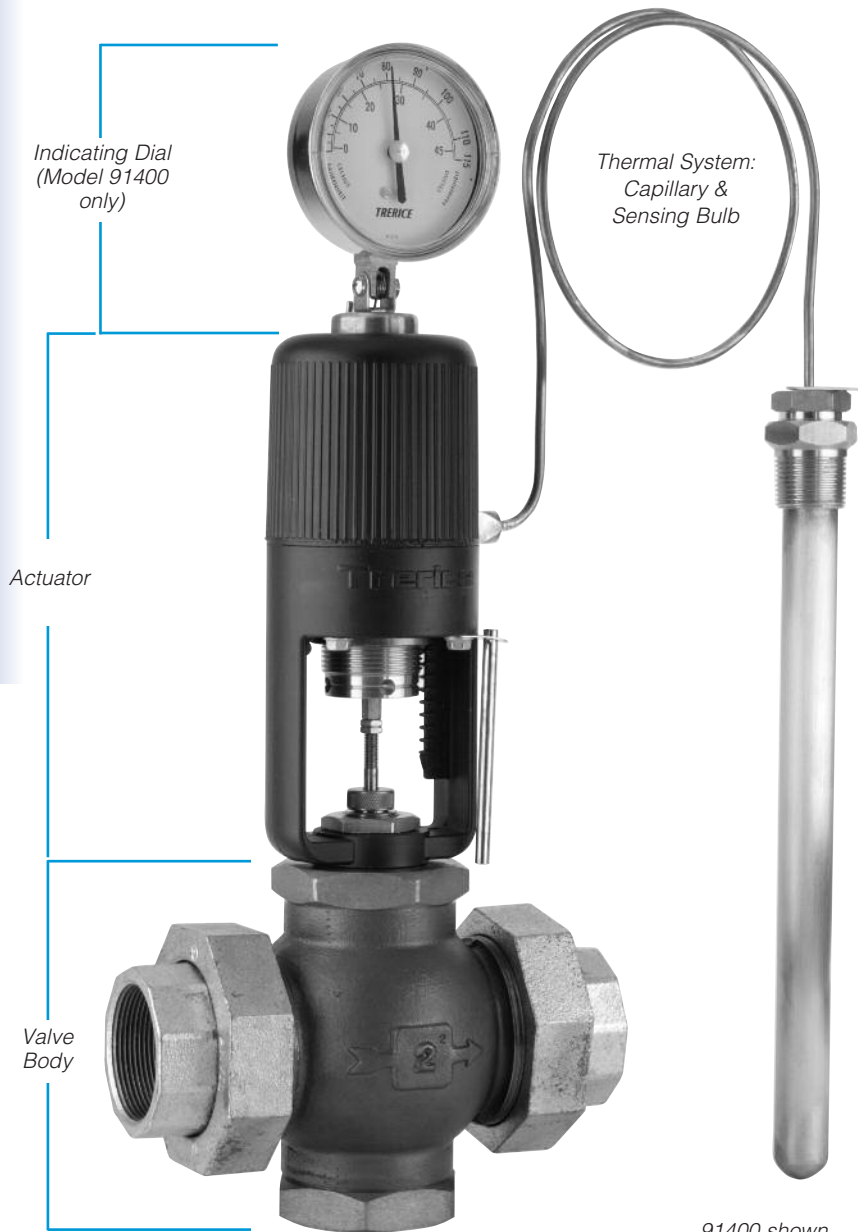

- ▶ Self-Operating Design
- ▶ Indicating, Non Indicating or Safety Models Available
- ▶ Heavy Duty Die Cast Aluminum Housing
- ▶ 1/2" thru 6" Valve Sizes
- ▶ Fully Enclosed Bellows
- ▶ Internal Overrange protection

The **91000 Series** (Models 91000, 91400 & 91600) Self-Operating Temperature Regulator is the preferred choice of original equipment manufacturers, mechanical contractors and specifying engineers. These regulators require no external power source and are ideal for regulating the temperature of tanks, process streams and various types of industrial equipment. The Actuator is noted for its rugged die-cast aluminum housing, fully enclosed bellows assembly and internal over range protection.

Valve bodies for the **91000** are offered in single-seated, double-seated and 3-way designs and are available in Bronze, Cast-Iron, Cast-Steel and Stainless Steel construction.

The Model **91000** (without indicating dial) features a lower profile and should be specified where space constraints may be an issue.

The Model **91400** (with indicating dial) will allow the operator to verify the process temperature and to aid in temperature adjustment.

The Model **91600** Fail-Safe Actuator is designed to cause the valve to fail in the safe control position (open in a cooling application, closed in a heating application) should accidental damage to the thermal system occur, resulting in loss of the pressure charge.

For optimal performance, the service conditions (medium, flow, temperature, inlet and outlet pressures) of the application must be considered when selecting a valve. Please refer to the Valve Selection Section of this catalog. For applications where the process media may be corrosive or contained under pressure, the use of a thermowell is required to prevent damage to the regulator bulb and facilitate its removal from the process. Improper application may cause failure of the valve, resulting in possible personal injury or property damage.

For replacement or service parts please see Accessories and Replacement Parts in the Regulators and Control Valves section of the list price sheet.

HOW TO ORDER

Sample Order Number: **91400 R06 08 B01 W01 - A26**

Models	Range	Capillary Length†	Thermal System	Thermowell**	Valve Body Selection
91000 Non-Indicating	Refer to	08 8 Feet	Refer to Thermal System Selection Chart (pages 186-187)	W01 - Brass	For 91000/91400 Models (refer to pages 188-195)
91400 Indicating Dial	Standard	12 12 Feet		W02 - Steel	
91600 Fail Safe	Ranges (page 184)	16 16 Feet		W04 - 316SS	For 91600 Models (refer to page 196) (Omit this selection if purchasing Actuator only)
		20 20 Feet		(Omit if not required)	

* Thermowell sized to fit bulb as specified. To purchase a thermowell separately, please consult Page 185.

† Other Capillary Lengths available: Specify in 4 Foot increments (52' maximum)

Specifications

Actuator Models

91000	(Non-Indicating)
91400	(Indicating Dial)
91600	(Fail-Safe)

Power Requirements

Fully self-contained –
no external power required

Dial Thermometer

3 1/2" dial, stainless steel case,
swivel and angle adjustment
(Model 91400 only)

Housing

Die cast aluminum, epoxy powder
coated blue finish

Set Point Scale

Integral to housing

Bellows

High pressure brass, corrosion
resistant, tin plated finish

Adjustment Screw

Brass

Adjustment Screw Bushing

Lubricant impregnated
sintered bronze

Range Adjustment Spring

Cadmium Plated

Overrange Protection

Upper range limit +100°F for
temporary situations
(not available for Model 91600)

Approximate Shipping Weight

Actuator

91000: 6.0 lbs [2.70 kg]
91400: 6.6 lbs [2.97 kg]
91600: 9.5 lbs [4.32 kg]

Valve

See Valve Selection tables

All dimensions are nominal. Dimensions in [] are in millimeters.

91000

Non-Indicating Actuator

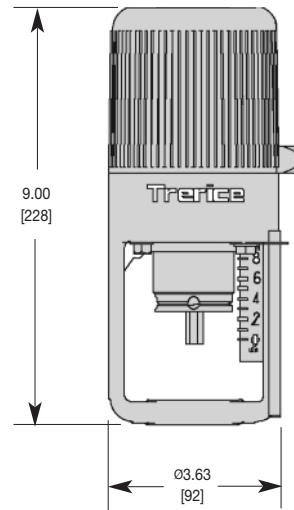

91400

Indicating Actuator

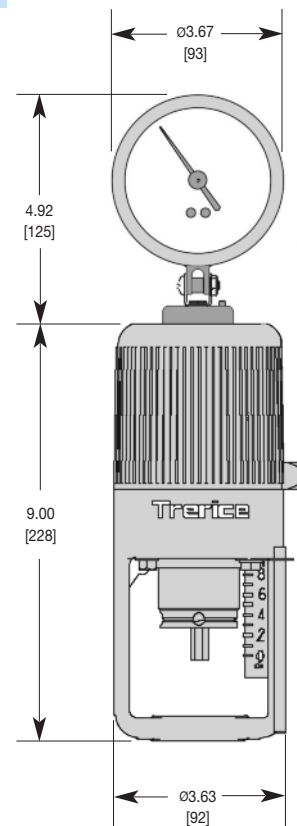

91600

Fail-Safe Actuator

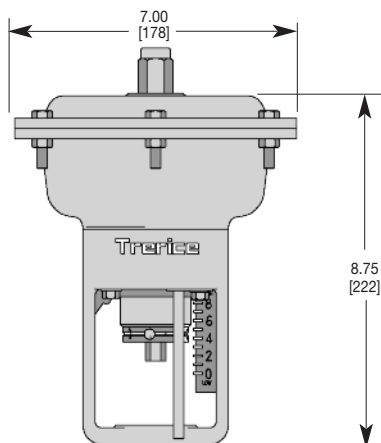

Valve Body Selection (for 91000 & 91400 Temperature Regulators)

CAST IRON

Double Seat • 2½" – 6"



All dimensions are nominal. Dimensions in [] are in millimeters.

TEMPERATURE REGULATORS

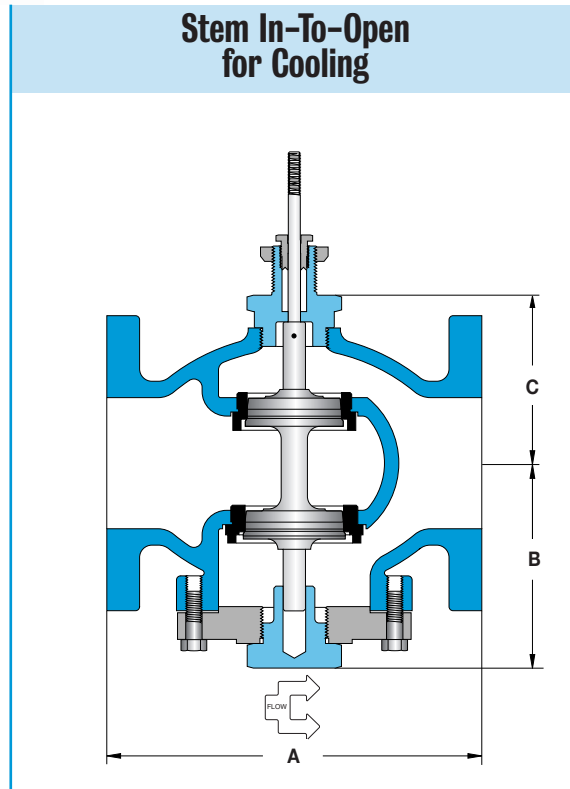
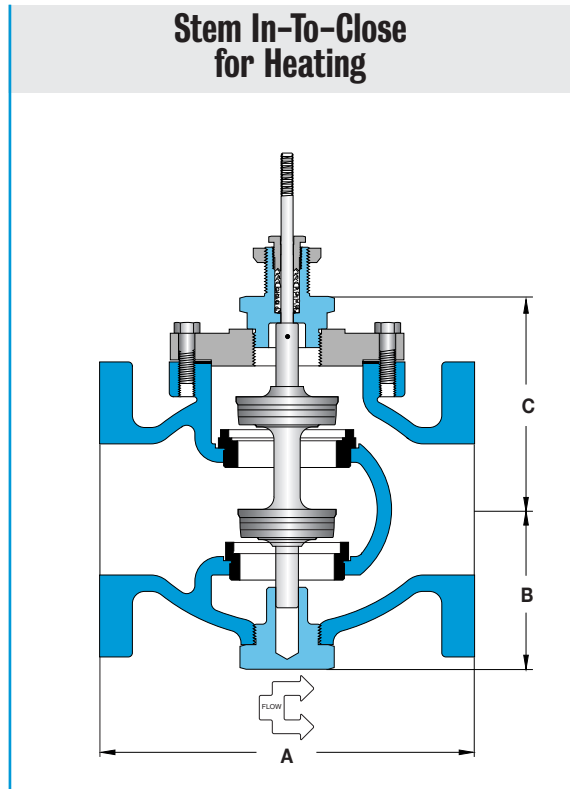

Specifications

Body Material	Trim Material	Trim Style	Connection	Pressure & Temperature Rating
Cast-iron	Stainless steel	Modified linear	Class 125 flanged	125 PSI @ 350°F (149°C)

Valve Body Selection

Valve Body Number		Size		Capacity Cv	Maximum Close-Off Pressure (psid)	Dimensions			Approximate Shipping Wt.
In-To-Close Heating	In-To-Open Cooling	Connection	Nominal Port			A	B	C	
B73	B74	2½"	2½"	69	65	7.8 [198]	4.8 [122]	5.4 [137]	45 lbs [20 kg]
B78	B79	3"	3"	90	50	9.0 [229]	5.0 [127]	5.6 [142]	70 lbs [32 kg]
B83	B84	4"	4"	196	40	11.4 [290]	6.3 [160]	6.5 [165]	100 lbs [45 kg]
B88	B89	5"	5"	248	30	12.0 [305]	6.9 [175]	7.3 [185]	155 lbs [70 kg]
B93	B94	6"	6"	340	25	14.1 [358]	7.5 [191]	8.0 [203]	180 lbs [82 kg]

ELGE®
Shell and Coil Heat Exchanger

Temperature Ranges

The “Self-Op” Temperature Regulator (91000, 91400, & 91600 Models)

Standard Ranges

91000 & 91400 Actuators					
Range Code	Nominal Range	Recommended Working Span			Dial Thermometer Range (Model 91400 only)
		Single Seat, In-To-Close Valves Double Seat, In-To-Close Valves Double Seat, In-To-Open Valves All 3-Way Valves	Single Seat In-To-Open Valves		
R01*	20° to 70°F & -10° to 20°C	40° to 65°F & 5° to 20°C	N/A		30° to 115°F & C
R02*	40° to 90°F & 5° to 30°C	65° to 85°F & 20° to 30°C	N/A		50° to 140°F & C
R03	30° to 115°F & 0° to 45°C	85° to 110°F & 30° to 45°C	50° to 80°F & 10° to 25°C		30° to 115°F & C
R04	50° to 140°F & 10° to 60°C	110° to 135°F & 45° to 60°C	80° to 105°F & 25° to 45°C		50° to 140°F & C
R05	75° to 165°F & 25° to 70°C	135° to 160°F & 60° to 70°C	105° to 130°F & 40° to 50°C		75° to 165°F & C
R06	105° to 195°F & 40° to 90°C	160° to 190°F & 70° to 90°C	130° to 155°F & 50° to 65°C		105° to 195°F & C
R07	125° to 215°F & 55° to 100°C	190° to 210°F & 90° to 100°C	155° to 180°F & 65° to 80°C		125° to 215°F & C
R09	155° to 250°F & 70° to 120°C	210° to 245°F & 100° to 120°C	180° to 215°F & 80° to 100°C		155° to 250°F & C
R10	200° to 280°F & 95° to 135°C	245° to 275°F & 120° to 135°C	215° to 245°F & 100° to 120°C		200° to 280°F & C
R11	225° to 315°F & 110° to 155°C	275° to 310°F & 135° to 155°C	245° to 280°F & 120° to 140°C		225° to 315°F & C
R12	255° to 370°F & 125° to 185°C	305° to 365°F & 155° to 185°C	275° to 335°F & 135° to 165°C		255° to 370°F & C
R13	295° to 420°F & 145° to 215°C	365° to 415°F & 185° to 215°C	335° to 385°F & 165° to 195°C		295° to 420°F & C
R14	310° to 440°F & 155° to 225°C	415° to 435°F & 215° to 225°C	385° to 405°F & 195° to 205°C		310° to 440°F & C

*Not recommended for single seated valves.

The recommended working span typically falls within the upper third of the nominal range. Single Seat In-To-Close, all Double Seat, and all 3-Way valves have a recommended working span in this part of the nominal range. However, due to differing thrust requirements, Single Seat In-To-Open valves have a recommended working span in the middle one-third of the nominal range.

Standard Ranges

91600 Fail-Safe Actuators		
Range Code	Nominal Range and Recommended Working Span	
R81	40° to 65°F	& 5° to 20°C
R82	55° to 80°F	& 15° to 25°C
R83	65° to 90°F	& 20° to 30°C
R84	80° to 110°F	& 25° to 40°C
R85	90° to 115°F	& 30° to 45°C
R86	110° to 140°F	& 40° to 60°C
R89	140° to 175°F	& 60° to 80°C
R90	170° to 195°F	& 80° to 90°C
R91	190° to 210°F	& 85° to 100°C
R92	205° to 225°F	& 95° to 105°C
R93	215° to 250°F	& 100° to 120°C
R94	230° to 265°F	& 110° to 130°C
R95	245° to 280°F	& 120° to 135°C
R96	270° to 300°F	& 135° to 150°C

ELGE®
Shell and Coil Heat Exchanger

Thermal System Selection

Temperature Regulator (91000, 91400, & 91600 Models)

U = Insertion Length
X = Bulb Length

TEMPERATURE REGULATORS

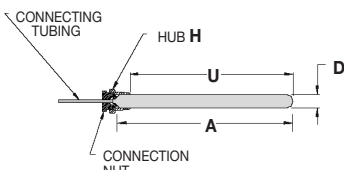
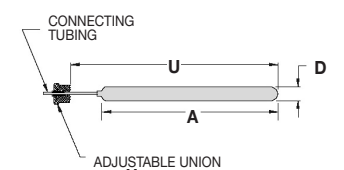
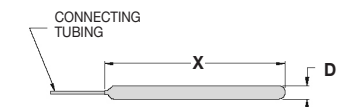
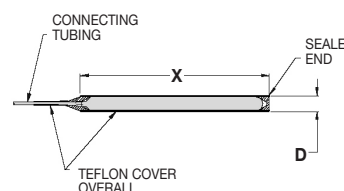
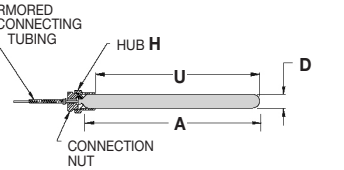
Bulb and Capillary Style	Order Code	Connection Style & Material	Bulb Material	Capillary Tubing Material
Union Connection				
	B01	Brass Union Hub	Copper	Copper
	B10	Stainless Steel Union Hub	Stainless Steel	Stainless Steel
Adjustable Union Connection				
	B02	Brass Union Hub	Copper	Copper
	B04	Stainless Steel Union Hub	Stainless Steel	Stainless Steel
Plain Bulb				
	B05	None	Copper	Copper
	B06	None	Stainless Steel	Stainless Steel
Teflon Covered Bulb				
	B08	None	Copper with Teflon Covering	Copper with Teflon Covering
	B07	None	Stainless Steel with Teflon Covering	Stainless Steel with Teflon Covering
Union Connection with Spiral Armor				
	B15	Brass Union Hub	Copper	Copper with Stainless Steel Spiral Armor
	B16	Stainless Steel Union Hub	Stainless Steel	Stainless Steel with Stainless Steel Spiral Armor

Bulb Pressure Limits: Copper = 250 psi, Stainless Steel = 500 psi

Bulb Dimensions & Minimum Insertion Lengths

Standard Bulb

Special "Small" Bulb

Dim.	91000 / 91400 Capillary Length				91600 Capillary Length 8 Feet*	91000 / 91400		91600
	8 to 16 Feet	20 Feet	24 to 36 Feet	40 to 52 Feet		Order Code	All	
A	13"	16"	20"	24"	16"	SB01	9"	12"
U	12.25"	15.25"	19.25"	23.25"	15.25"		8.25"	11.25"
D	1"	1"	1"	1"	1"		3/4"	3/4"
H	1 NPT	1 NPT	1 NPT	1 NPT	1 NPT		3/4 NPT	3/4 NPT
A	13"	16"	20"	24"	16"	SB10	9"	12"
U	12.25"	15.25"	19.25"	23.25"	15.25"		8.25"	11.25"
D	1"	1"	1"	1"	1"		3/4"	3/4"
H	1 NPT	1 NPT	1 NPT	1 NPT	1 NPT		3/4 NPT	3/4 NPT
A	13"	16"	20"	24"	16"			
U	12.25"	15.25"	19.25"	23.25"	15.25"			
D	1"	1"	1"	1"	1"			
H	1 NPT	1 NPT	1 NPT	1 NPT	1 NPT			
X	13"	16"	20"	24"	16"			
D	1"	1"	1"	1"	1"			
X	13"	16"	20"	24"	16"			
D	1"	1"	1"	1"	1"			
X	15"	18"	22"	26"	18"			
D	1.16"	1.16"	1.16"	1.16"	1.16"			
X	15"	18"	22"	26"	18"			
D	1.16"	1.16"	1.16"	1.16"	1.16"			
A	13"	16"	20"	24"	16"	SB15	9"	12"
U	12.25"	15.25"	19.25"	23.25"	15.25"		8.25"	11.25"
D	1"	1"	1"	1"	1"		3/4"	3/4"
H	1 NPT	1 NPT	1 NPT	1 NPT	1 NPT		3/4 NPT	3/4 NPT
A	13"	16"	20"	24"	16"	SB16	9"	12"
U	12.25"	15.25"	19.25"	23.25"	15.25"		8.25"	11.25"
D	1"	1"	1"	1"	1"		3/4"	3/4"
H	1 NPT	1 NPT	1 NPT	1 NPT	1 NPT		3/4 NPT	3/4 NPT

TEMPERATURE REGULATORS

Note: This bulb is available for applications where space considerations exist, and may only be used when the temperature of the actuator housing will always remain lower than that of the sensing bulb. If the temperature of the actuator housing rises above the sensing bulb temperature, the unit will not operate properly. The temperature of the actuator housing is dependent upon both the surrounding environment and the temperature of the flow medium and may easily reach 150°F on steam service.

This bulb is only available on union connected thermal systems.

Always use the Standard Bulb unless special requirements exist and full details of the application are known, consult factory.

*On Model 91600, Minimum Insertion Length increases by 1" for each additional 4 ft. capillary increment.

for Temperature Regulator (91000, 91400, & 91600 Models)

If Thermowells are to be purchased as a separate item, or if a Special Thermowell is required, please refer to this page. If a complete Temperature Regulator is purchased, the proper Thermowell to match the sensing bulb ordered will be supplied. Please note sensing bulb size is affected by capillary length. Indicate W01 for Brass, W02 for Steel or W04 for 316SS.

Thermowell to fit Standard Bulb

All dimensions are nominal. Dimensions in [] are in millimeters.

Threaded

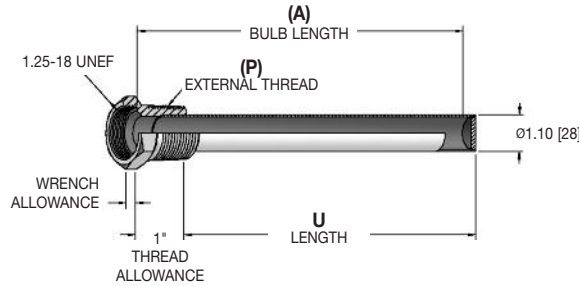

Flanged

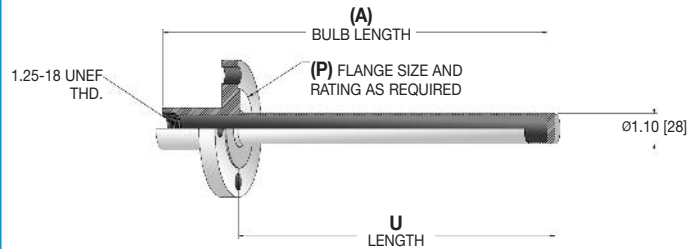

Pressure Rating (psi)

Material	Operating Temperature		
	70°F	300°F	500°F
Carbon Steel	780	780	600
316 Stainless Steel	750	690	600
Brass	350 psi @ 150°F, 280 @ 350°F		

Lengths

(A) BULB LENGTH	U Length
13"	12.25 [311]
16"	15.25 [387]
20"	19.25 [489]
24"	23.25 [591]

Maximum pressure and temperature ratings are limited by the choice of flange. Please see ANSI/ASME B16.5-2003 for more information.

HOW TO ORDER

Sample Order Number: **53-6S6**

Thermowell Style	(P) External Connection	(A) Bulb Length	Material
53 - Temperature Regulator	6 1 1/4 NPT	S 13" Bulb	2 Brass (500 psi max.)
	71 1 1/2" 150# RFF *	Se 16" Bulb	3 Steel (500 psi max.)
	81 2" 150# RFF *	We 20" Bulb	6 316SS (1000 psi max.)
	181 3" 150# RFF *	Wk 24" Bulb	

* Not available in Brass.

Other connections and lengths may be available, consult factory.

Thermowell to fit Special "Small" Bulb

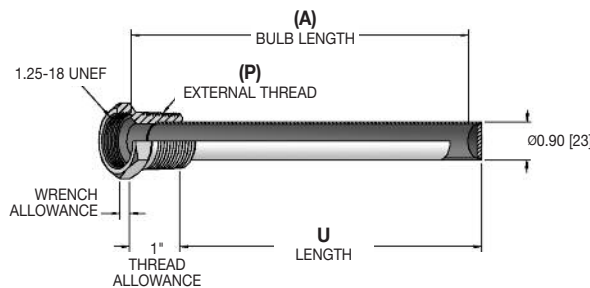

Lengths

(A) Bulb Length	Thermowell U Length
9"	8.25 [210]
12"	11.25 [286]

Pressure Rating (psi)

Material	Operating Temperature		
	70°F	300°F	500°F
Carbon Steel	850	850	680
316 Stainless Steel	850	780	730
Brass	480 psi @ 150°F, 400 @ 350°F		

HOW TO ORDER

Sample Order Number: **53-5M2**

Thermowell Style	(P) External Thread	(A) Bulb Length	Material
53 - Temperature Regulator	5 1 NPT	M 9" Bulb	2 Brass (500 psi max.)
		R 12" Bulb	3 Steel (500 psi max.)
			6 316SS (1000 psi max.)

Selection of the proper thermowell is the sole responsibility of the user. Pressure limitations must be considered. Improper application may cause failure of the thermowell, resulting in possible personal injury or property damage.



STEAM SPECIALTIES

Float & Thermostatic Trap, Double Inlet/Double Outlet - Series 44 & 45

APPLICATION

The MEPCO Series 44 & 45, Float & Thermostatic Trap with Double Inlet/Double Outlet configuration, is applicable to all types of steam heating systems and steam process equipment. These traps operate efficiently with pressures up to 15 lbs. for lower pressure applications and up to 125 PSI for higher pressure applications. Their purpose is to move air and water while preventing steam from entering the return piping.

These traps are manufactured in four sizes (3/4", 1", 1-1/4" & 1-1/2") for handling capacities of 300 to 4,300 lbs. of condensate per hour. Four (4) possible connections allow a greater flexibility in piping. These traps can be piped in and out from either side, for a total of four piping combinations depending on your particular needs. All working parts are made of non-corrosive metals especially adapted for this service, and each trap is individually tested for reliable operation.



Series 44 Float & Thermostatic Trap (Double Inlet/Double Outlet)

FEATURES & BENEFITS

- 1. Simple, rugged construction.** This *MEPCO* trap consists of a body, cover and float valve assembly. Body and cover are cast iron; all working parts are made of non-corrosive metals especially adapted for this service.
- 2. Sensitive thermostatic action.** Charging the thermostatic disc under high vacuum assures sensitive and positive response to temperature and pressure over entire operating range. Disc corrugations are shaped to reduce hinge action at the rim of the disc and evenly distribute disc motion.
- 3. Instantaneous valve action.** Design of the float valve assembly permits rapid and positive valve action.

Location of the valve assures a deep water seal at all times.

4. Continuous rapid flow of water. A lever operated discharge valve opens wide so that large volumes of water can flow continuously from trap.

5. Thorough testing. In addition to tests made of the completed trap, each thermostatic disc is tested before it is assembled into the trap.

6. Minimum maintenance. All working parts may be inspected, removed or repaired without disturbing piping connections. Clean-out plug at bottom of trap body permits easy flushing of dirt.

PARTS/MATERIALS - 44 & 45 series traps

ITEM	PART	MATERIAL
1	Body	Class 30 Cast Iron
2	Cap	Class 30 Cast Iron
3	Disc (series 44)	Stainless Steel & Brass
3	Plug (series 45)	Brass
4	Hinge	Brass
5	Pin, hinge	Stainless Steel
6	Gasket	Non-asbestos Fiber
7	Seat	SST, Brass holder
8	Valve	Stainless Steel
9	Clip	Stainless Steel
10	Lever & Float Assy	Stainless Steel
11	Plug 1/4" NPT	Steel

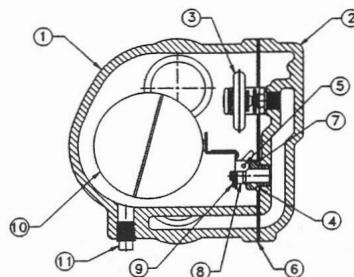

44 SERIES F&T TRAPS ASSEMBLY DRAWING

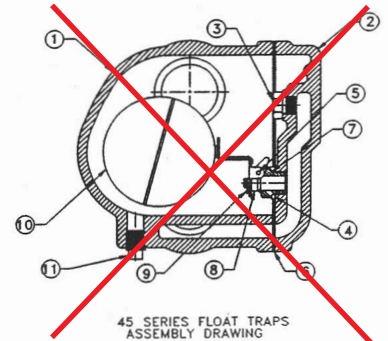

45 SERIES FLOAT TRAPS ASSEMBLY DRAWING

Dimensions and Capacities

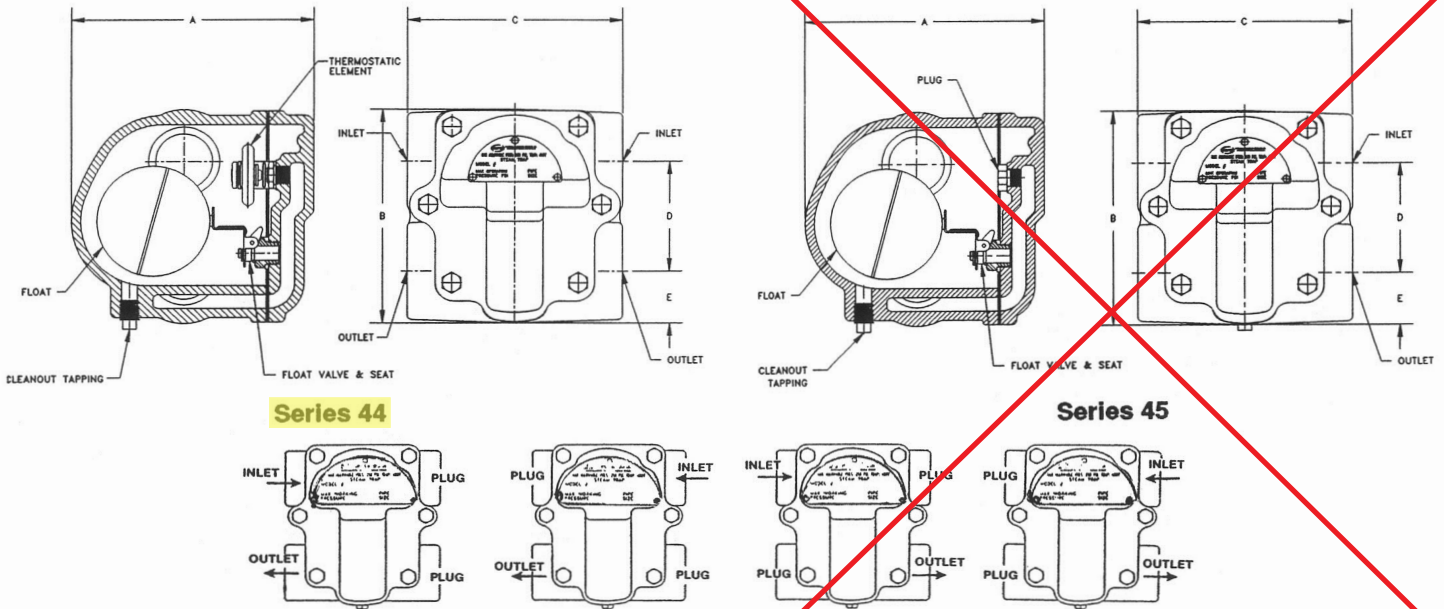

Dimensions

TRAP NO.	TAPPING	A	B	C	D	E	F	G	NET WGT.(lb.)
44/45-2	3/4"	5-3/4	5-11/16	4-7/8	3-3/8	1-5/32	5-13/16	--	12
44/45-4	1"	5-3/4	5-11/16	4-7/8	3-3/8	1-5/32	5-13/16	-	12
44/45-5	1-1/4"	6-3/8	5-3/4	5-3/8	3	1-3/8	6-3/4	--	17
44/45-7	1-1/2"	6-3/8	5-3/4	5-3/8	3	1-3/8	6-3/4	--	17

Capacities

	Model -215A			-230A			-275A			-2125A		
	No. -415A	-515A	-715A	-430A	-530A	-730A	-475A	-575A	-775A	-4125A	-5125A	-7125A
NPT Size	3/4"/1"	1-1/4"	1-1/2"	3/4"/1"	1-1/4"	1-1/2"	3/4"/1"	1-1/4"	1-1/2"	3/4"/1"	1-1/4"	1-1/2"
Orifice	.313	.344	.391	.250	.313	.391	.141	.188	.219	.109	.141	.172
1/4	600	750	980	425	600	800	300	375	400	275	300	350
1/2	825	1,000	1,365	600	825	1,100	375	500	525	310	375	450
1	1,000	1,200	1,855	750	1,000	1,450	425	600	675	350	425	550
2	1,225	1,400	2,410	900	1,225	1,800	500	710	825	390	525	650
5	1,575	1,900	3,150	1,250	1,575	2,400	625	935	1,075	450	625	800
10	1,875	2,300	3,750	1,500	1,875	2,900	725	1,050	1,250	500	725	950
15	2,175	2,700	4,075	1,725	2,175	3,400	825	1,225	1,425	540	825	1,050
20				1,900	2,500	3,750	900	1,375	1,575	600	900	1,150
25				2,050	2,750	4,050	975	1,525	1,725	660	975	1,275
30				2,300	3,000	4,300	1,000	1,675	1,850	725	1,100	1,400
40							1,200	1,825	2,000	850	1,200	1,500
50							1,350	1,950	2,200	1,000	1,350	1,625
60							1,500	2,100	2,400	1,100	1,500	1,780
75							1,650	2,400	2,700	1,280	1,650	1,950
90										1,410	1,825	2,100
100										1,500	1,900	2,275
125										1,650	2,100	2,500

Capacities given are continuous discharge in pounds of condensate per hour at pressure differential indicated, determined by tests conducted according to ASME Performance test Code 39.1-1980. Apply Safety Factor as required per application. Condensate within 5 degrees of steam temperature.



MARSHALL ENGINEERED PRODUCTS CO.



SPECIALTIES

Strainers, Cast Iron Type SS-A

APPLICATION

The MEPCO Strainers are applicable to all types of steam and hot water heating systems. Their purpose is to protect traps, valves, heating elements, pumps, piping, etc. from dirt and scale which are often times the cause of a loss of heating efficiency.



STRAINER, Type SS-A

FEATURES

Cast Iron Strainer

- Simple, rugged construction.** Strainer consists of a heavy iron casting with removable sieve and cover. Sieve is formed of perforated stainless steel sheet with .065 in. diameter holes, 100 per square inch. Special screens are furnished at slight extra cost. Strainer sieve cover is a cast iron bushing.
- Easily cleaned.** Removable cover is located at bottom of strainer. Sieve is easily removed for cleaning.
- Full range of sizes.** Strainer is manufactured in 1/2" thru 2" sizes. Strainer sieve cover is tapped for blow-off connection.
- Operating Pressures.** For operating pressures up to 250 PSI for cast iron strainers.

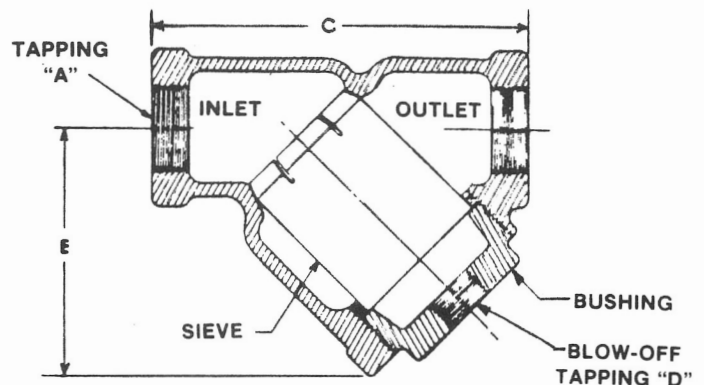

STRAINER Type SS-A

STRAINER TYPE	CONNECTION	SIZE "A"	DIMENSIONS					SHIPPING WEIGHT (LBS.)
			B	C	TAPPING D	E	OVERALL WIDTH	
SS-A	Screwed	1/2"	—	3-7/16"	3/8"	2-3/8"	2"	1-1/2
	Screwed	3/4"	—	4-1/2"	3/8"	2-1/2"	2"	1-3/4
	Screwed	1"	—	4-3/4"	1/2"	3-1/16"	2-7/16"	2-3/4
	Screwed	1-1/4"	—	5-1/4"	1/2"	3-1/4"	2-7/16"	3-1/2
	Screwed	1-1/2"	—	6-1/8"	1/2"	4"	3-5/16"	5-1/2
	Screwed	2"	—	6-1/8"	1/2"	4-1/4"	3-5/16"	7-1/2

WHEN ORDERING OR SPECIFYING, INDICATE: (1) Strainer Type, (2) Size

For Commercial Water Heater Applications

Series 40, 140, 240 & 340 Automatic Re-seating T&P Relief Valves

The combined 2-in-1 Temperature & Pressure Relief Valve provides the least expensive and proven means for protection against both excessive temperature and pressure emergency conditions.

Fully automatic temperature and pressure relief protection for domestic hot water supply tanks and heaters based on the latest ANSI Z21.22 Listing requirements for temperature discharge capacity.

40XL with test lever and extension thermostat for installation in hot water outlet within the allowable distance from the top of the tank based on latest ANSI Z21.22. Sizes 3/4" and 1" (20 – 25mm).

40L with test lever and short thermostat for installation directly in available tank tappings. Sizes 3/4" and 1" (20 – 25mm).

Series 140, N240 and 340 have the same basic body construction and advanced design features as the Series 40 and are identical to the Series 40 except for discharge capacity and size of inlet and outlet connections. For complete specifications (including specifications for the Series 40) see other side. Sizes 1", 1 1/4", 1 1/2" and 2" (25, 32, 40 and 50mm).

Features

- Bronze body construction
- Non-mechanical seat-to-disc alignment
- Thermostat is accurate and proven. Exclusively designed and manufactured by Watts
- Tamper-resistant bonnet screws
- Series 40 and 140 feature a unique thermostat with a special thermo-bonded coating
- Series 140 sizes 1" (25mm) and above are standardly furnished with stainless steel thermostat tube

Specifications

Temperature & Pressure Relief Valves

Each hot water storage heater shall be equipped with an automatic temperature and pressure relief valve to protect the heater from excessive pressure and excessive temperature. The device shall be certified as meeting the requirements of ASME low pressure heating boiler code and ANSI Z21.22. The BTU discharge capacity of the device shall be in excess of the BTU input rating of the heater. The T&P valve shall be a Watts Regulator Company Series 40, 140, 240 or 340.

Standards



ASME Rated, ANSI Z21.22, Design certified and listed by CSA, National Board of B&PVI to Section IV of the ASME B&PV code and meet current FHA requirements and ANSI Z21.22 in addition to Military Spec. MIL-V-136-12D, Type I.

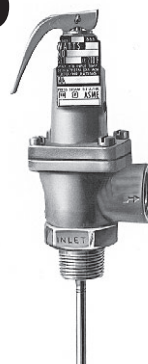

Series 40L and 40XL



Series 140X



Series N240X



Series 340

Pressure – Temperature

Temperature relief 210°F (99°C)

Pressure range 75 – 150psi (5.2 – 10.3 bar)

Standard setting 75, 100, 125 and 150psi

(5.2, 6.9, 8.6 and 10.3 bar)

Following installation, the valve lever MUST be operated AT LEAST ONCE A YEAR by the water heater owner to ensure that the waterways are clear. Certain naturally occurring mineral deposits may adhere to the valve, blocking waterways, rendering it inoperative. When the lever is operated, Hot water will discharge if the waterways are clear. Precautions must be taken to avoid personal injury from contact with hot water and to avoid property damage.

IMPORTANT: INQUIRE WITH GOVERNING AUTHORITIES FOR LOCAL INSTALLATION REQUIREMENTS

Direct Side Tapping

FOR EXTERNAL FLUE HEATERS

Use extra length extension thermostat to extend into water storage tank.

FOR INTERNAL FLUE HEATERS

Use short or standard length thermostat. Vertical discharge line must be installed with its direction downward.

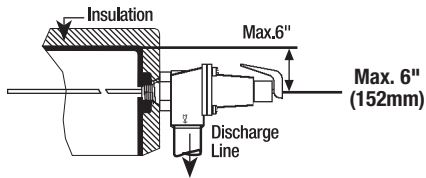

For Heaters with Direct Top Tapping

Use standard or extra length extension thermostat.

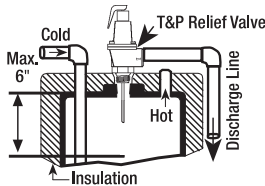

General Recommendations†

For gas, electric or oil-fired storage water heaters between 180,000 to 205,000 BTU/Hr. rating: **Use ¾" (20mm) Series 40, 140 tested under ANSI Z21.22 with ratings as certified and listed by CSA.**

For gas or oil-fired storage water heaters between 205,000 and 730,000 BTU/Hr. rating and for compliance with applicable water heater labeling requirements: **Use 1" (25mm) 40, 140, N240 Series tested under ANSI Z21.22 with ratings as certified and listed by CSA.**

For installations of gas or oil-fired hot water supply boilers over 730,000 BTU/Hr. output heating domestic water and for steam coil storage water heaters: **Use Series 340, 342 tested under ANSI Z21.22 with rating as certified and listed by CSA.**

SPECIAL MODEL: No. 340X-8 M4Z 1½" (40mm) size only. Pressure setting 175psi (5.2 bar). Temp. 210°F (99°C). Certified by CSA only.

Model	Inlet X Outlet (in.)	Thermostat Length (in.) (Below Inlet thread)	Dimensions (in.)		Weight Lbs.	CSA Temp. Steam Rating BTU/HR	**ASME PRESSURE STEAM RATING BTU/HR			
			Height (Less Thermostat)	Width			@75psi set pres.	@100psi set pres.	@125psi set pres.	@150psi set pres.
40L-3	¾ M x ¾ F	3	5½	2½	1¾	180,000	777,600	997,600	1,217,600	1,437,600
40XL-5	¾ M x ¾ F	5	5½	2½	1¾	205,000	777,600	997,600	1,217,600	1,437,600
40XL-8	¾ M x ¾ F	8	5½	2½	1¾	205,000	777,600	997,600	1,217,600	1,437,600
140S-3	¾ F x ¾ F	3	5½	2½	1¾	180,000	777,600	997,600	1,217,600	1,437,600
140X-5	¾ F x ¾ F	5	5½	2½	1¾	205,000	777,600	997,600	1,217,600	1,437,600
140X-8	¾ F x ¾ F	8	5½	2½	1¾	205,000	777,600	997,600	1,217,600	1,437,600
40L-2	1M x 1F	2	6¼	2¾	2¼	450,000	1,155,000	1,481,000	1,808,000	2,134,000
40XL-4	1M x 1F	4	6¼	2¾	2¼	500,000	1,155,000	1,481,000	1,808,000	2,134,000
40XL-7	1M x 1F	7	6¼	2¾	2¼	500,000	1,155,000	1,481,000	1,808,000	2,134,000
*140S-3	1F x 1F	3	5½	3	2¼	570,000	1,670,000	2,140,000	2,610,000	3,085,000
*140X-6	1F x 1F	6	5½	3	2¼	670,000	1,670,000	2,140,000	2,610,000	3,085,000
*140X-9	1F x 1F	9	5½	3	2¼	670,000	1,670,000	2,140,000	2,610,000	3,085,000
*N240X-6	1F x 1F	6	6½	3¾	2¾	730,000	2,195,000	2,817,000	3,438,000	4,059,000
*N240X-9	1F x 1F	9	6½	3¾	2¾	730,000	2,195,000	2,817,000	3,438,000	4,059,000
*N241X-5	1¼ M x 1F	5	6½	3¾	2¾	730,000	2,195,000	2,817,000	3,438,000	4,059,000
*N241X-8	1¼ M x 1F	8	6½	3¾	2¾	730,000	2,195,000	2,817,000	3,438,000	4,059,000
*340-3	1½ F x 1½ F	3	9¾	4½	7	1,150,000	3,450,000	4,426,000	5,403,000	6,379,000
*340X-8	1½ F x 1½ F	8	9¾	4½	8	1,150,000	3,450,000	4,426,000	5,403,000	6,379,000
*342-3	2 M x 1½ F	3	9¾	4½	7	1,150,000	3,450,000	4,426,000	5,403,000	6,379,000
*342X-8	2 M x 1½ F	8	9¾	4½	8	1,150,000	3,450,000	4,426,000	5,403,000	6,379,000

*Standardly furnished with stainless steel thermostat tube.

M = Male

F = Female

**ASME capacities are steam pressure ratings and do not reflect the CSA temperature relieving capacity of the valves for selection purposes.

†LL40XL and LLL40XL valves with extended inlet shanks should be used for water heaters that have extra thick insulation, Ask for ES-LL/LLL-40XL.

Temperature and Pressure Relief Valves should be inspected AT LEAST ONCE EVERY THREE YEARS, and replaced, if necessary, by a licensed plumbing contractor or qualified service technician, to ensure that the product has not been affected by corrosive water conditions and to ensure that the valve and discharge line have not been altered or tampered with illegally. Certain naturally occurring conditions may corrode the valve or its components over time, rendering the valve inoperative. Such conditions can only be detected if the valve and its components are physically removed and inspected. Do not attempt to conduct an inspection on your own. Contact your plumbing contractor for a reinspection to assure continuing safety.

WATTS®

A Watts Water Technologies Company



**ISO 9001-2000
CERTIFIED**

USA: 815 Chestnut St., No. Andover, MA 01845-6098; www.watts.com

Canada: 5435 North Service Rd., Burlington, ONT. L7L 5H7; www.wattscanada.ca

FW and FWC Miniature Relief Valves

DESCRIPTION

The Cash Acme FW and FWC miniature relief valves are designed for commercial and industrial applications including thermal expansion protection, static pressure and over-pressure relief, very low capacity pump relief, and other uses of similar nature where tight shut-off is required.

The Cash Acme FW and FWC Valves are small and low-cost non-code relief valves. They are available in 1/2" and 3/4" sizes with male inlet and female outlet.

The FW and FWC valves have standard factory pressure settings of 125 psi. The FWC has an external adjusting screw which allows for occasional changes in pressure setting.

The Cash Acme FW and FWC Valves feature a brass body, silicone seat disc, and stainless steel pressure spring.

Lead Free* versions of FWC models are also available.



FEATURES AND BENEFITS

Offers protection against problematic and over-pressure conditions:

Thermal expansion protection, static pressure and over-pressure relief, very low capacity pump relief and other uses of similar nature where tight shut-off is required.

Commercial and industrial applications:

Designed to meet the needs of a wide variety of water systems.

Every valve is tested for performance prior to shipping:

Specify and install with confidence!

SPECIFICATIONS

FW: A miniature relief valve shall be installed to relieve pressure for applications where tight shut-off is required. The valve shall be of brass construction with a male inlet and female outlet. The valve shall have a silicone seat disc and a stainless steel pressure spring. The valve shall be a Cash Acme FW Relief Valve.

FWC: A miniature relief valve shall be installed to relieve pressure for applications where tight shut-off is required. The valve shall be of brass construction with a male inlet and female outlet. The valve shall have a silicone seat disc and a stainless steel pressure spring. The valve shall have an external adjusting screw to allow changes to the set pressure. The valve shall be a Cash Acme FWC Relief Valve.

* A device is defined as Lead Free if its normally wetted surface has a weighted average lead content not exceeding 0.25%

FW and FWC Miniature Relief Valves

TYPICAL INSTALLATION

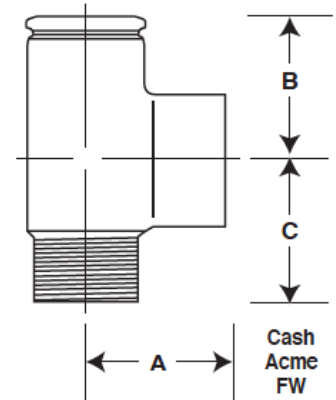
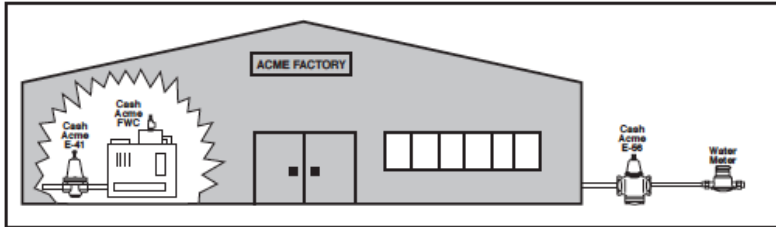

SPECIFICATION DATA

Performance:

Set pressure range 15 - 200 psi (Type FW) and
 25 - 175 psi (Type FWC) factory set at 125 psi
 Maximum temperature 210° F
 Service Water

Materials:

Body Brass
 Pressure Spring Stainless steel
 Seat Disc Silicone

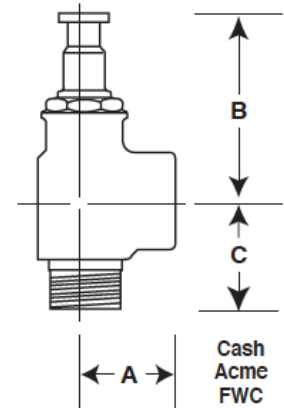

CONNECTIONS

Threaded (NPT) Male inlet and female outlet

CERTIFICATIONS

The Cash Acme FW and FWC miniature relief valves are non-code valves.

Dimensions	A	B	C
FW - 1/2"	1 3/16"	1 11/32"	1 1/2"
FW - 3/4"	1 3/16"	1 11/32"	1 1/2"
FWC - 1/2"	1 3/16"	2 5/8"	1 1/2"
FWC - 3/4"	1 1/4"	2 5/8"	1 1/2"



VENT-RITE AIR VALVES PUT QUALITY ON THE LINE!



- Every Vent-Rite Valve is factory assembled, tested & inspected in the U.S.A.
- Each valve is individually packaged with external labeling for convenience and maintenance
- All brass internals with nickel plated and hand polished exterior.
- Adjustable vents have wide adjustment conveniently located below steam path



Air Valves For Steam Systems

QUICK, UNIFORM DISTRIBUTION OF HEAT TO ALL RADIATION IS THE FIRST ESSENTIAL TO PERFECT PERFORMANCE. THIS REQUIRES BALANCING THE RADIATION BY CONTROLLED VENTING. VENT-RITE'S #1 NON-VACUUM VENTS ARE ADJUSTABLE AND ALL VENTS ARE DESIGNED FOR POSITIVE ACTION AND STRAIGHTLINE VENTING. THEY FUNCTION AUTOMATICALLY TO VENT THE AIR. IF, THROUGH AN UNUSUAL CONDITION, THE VENT IS FILLED WITH WATER, THE VENT PORT AUTOMATICALLY CLOSES.

VENT-RITE REPLACEMENT GUIDE		
VENT-RITE	DOLE	HOFFMAN
1 11	1A 1933	1A 40
31 33	3A 3B	41 43
35 75 77	4 3C 5	45 45 45
57	55	74

VENT-RITE NON-VACUUM VENTS						
USE FOR	NO.	CONNECTION	VENT PORT	OPER. PRES.	O.A. HT.	ADJ.
FREE STANDING RADIATORS	1	1/8" MALE	3/32"	3 PSI	3 1/4"	YES
	11		1/16"	6 PSI	2 3/4"	-
CONVECTOR AND RISERS	31	1/8" MALE	1/16"	6 PSI	3 3/4"	-
	33	1/4" MALE	1/16"	6 PSI	3 3/4"	-
MAIN VENTS	35	3/4" MALE X 1/2" FEMALE	3/32"	3 PSI	3 1/4"	-
	75		3/32"	5 PSI	4 5/8"	-
	77		1/8"	3 1/2 PSI	4 5/8"	-
UNIT HEATERS	57	3/4" MALE X 1/2" FEMALE	1/32"	20 PSI	4 5/8"	-
	NOTE:		#57 ALSO REDUCES DAMAGE CAUSED BY WATER HAMMER			

OPERATING PRESSURE (DROP AWAY) IS THE MAXIMUM PRESSURE AT WHICH THE VENT WILL CONTINUE TO OPEN AND CLOSE DUE TO THE CHANGE OF TEMPERATURE. THE VENT MAY BE USED WITH SLIGHTLY HIGHER PRESSURE PROVIDING IT DROPS BELOW THE OPERATING PRESSURE BETWEEN EACH FIRING CYCLE.

PAXTON

C O R P O R A T I O N



Domestic Hot Water

MIXING VALVE SYSTEMS



Paxton TVS43 and TVS43R Systems

- Accurate control of domestic hot water during all flow conditions
- Easy to install and retrofit, simple start-up with default settings
- Direct replacement for TAC 239W tempering system
- Rugged lead free stainless steel valves
- Unique low load algorithm keeps temperature steady in low demand periods
- TVS43R features a fail closed actuator, providing protection from temperatures over setpoint and on power loss without use of additional valves and sensors
- Modbus communication standard, easy integration to BMS systems
- Prevents the risk of legionella bacteria growth
- ASSE 1017 and NSF 372 Listed

Applications

- Apartment Houses
- Schools and Dormitories
- Office Buildings
- Co-Gen Plants
- Hotels
- Industrial and Process Applications
- Nursing Homes
- DHW Solar Systems

Purpose

Temperature control - TVS series provides accurate control of domestic hot water system ensuring all branches of the system are at the desired temperature.

Bacteria elimination - By continuously monitoring the temperature of the mixed outlet, hot water tanks and coils can be stored safely at elevated temperatures preventing the growth of bacteria.

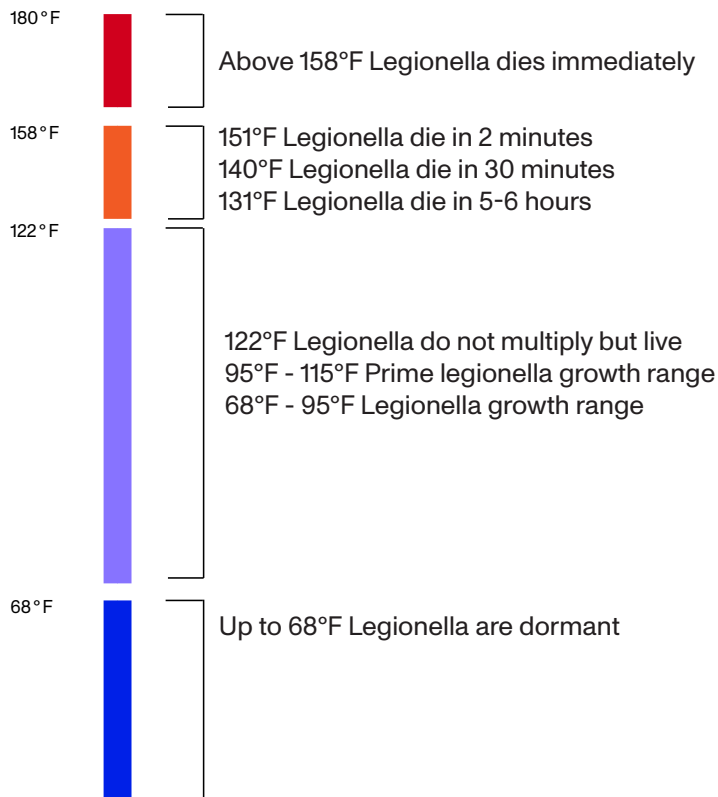

Temperature	Time to scald
120°F	5+ minutes
125°F	1.5 to 2 minutes
130°F	30 seconds
135°F	10 seconds
140°F	Less than 5 seconds
145°F	Less than 3 seconds
150°F	1.5 seconds
155°F	1 second

Technical Data

Operating Voltage 24 VAC
 Control Signal 0-10 Vdc or 2-10 Vdc
 Action Direct or reverse acting
 Actuator Force 180 lbs or 330 lbs
 Actuator Run Time 20 Seconds
 Sensor Sampling Rate 10 samples per second

Each system consists of:

TC250D PI Controller with LED readout
 STP120-70 Fast Immersion Sensor 1/2" NPT
 VM800 or VM900 20 Second Actuator
 V43 Valve SS Valve Body
 TVS-TRN 120/24VAC Transformer
 TC250EN NEMA 5 Enclosure

Selection

TVS43



TVS43R
w/ fail closed actuator

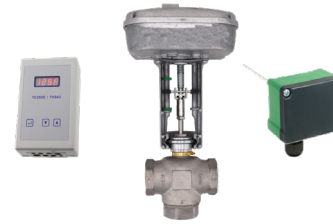

TVS43	TVS43R	Size	Cv
TVS43-020	TVS43R-020	3/4"	7.3
TVS43-025	TVS43R-025	1"	11.6
TVS43-032	TVS43R-032	1 1/4"	18.5
TVS43-040	TVS43R-040	1 1/2"	29.0
TVS43-050	TVS43R-050	2"	46.3
TVS43-065	TVS43R-065	2 1/2"	65.0

Layout

See installation manual for full wiring and piping detail.
If desired, hot and cold ports can be swapped.

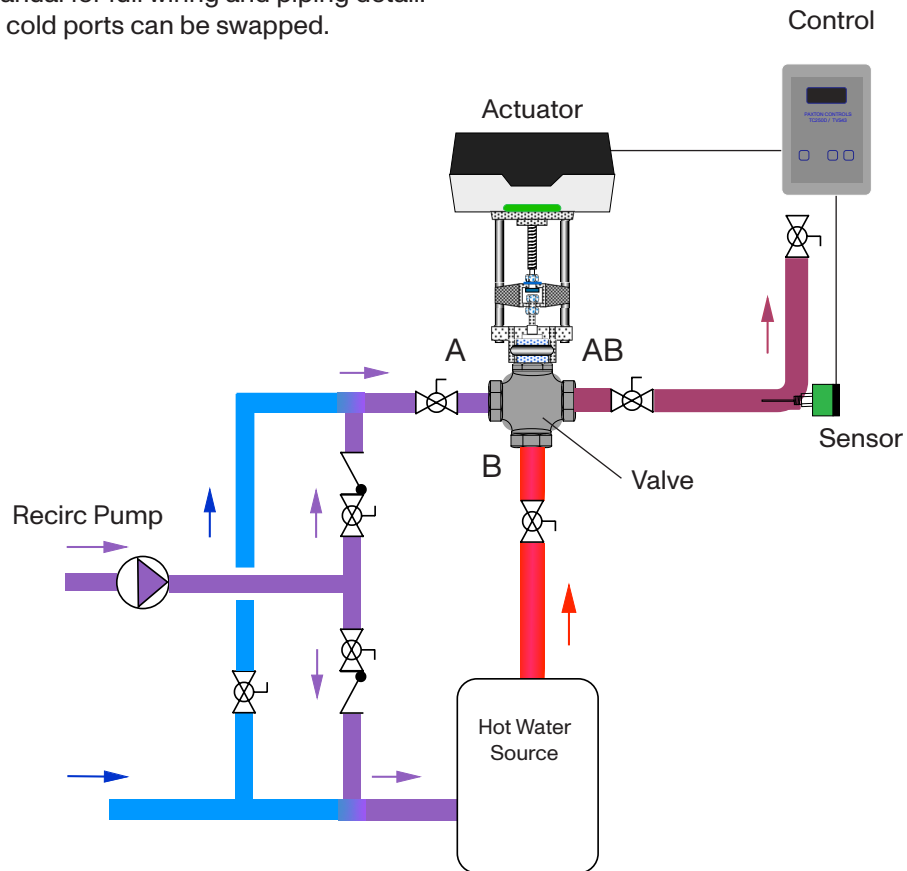

Sizing

Flow in GPM vs pressure drop in valve

Size	Cv	5 PSI	7 PSI	10 PSI	15 PSI	20 PSI
3/4"	7.3	17	19	23	28	32
1"	11.6	26	31	37	45	50
1-1/4"	18.5	42	49	59	72	80
1-1/2"	29.0	66	77	92	112	126
2"	46.3	105	123	147	179	201
2-1/2"	65.0	148	172	206	252	283

Systems should be sized for a 5 to 10 PSI pressure drop for best performance

Approximate valve sizing

for multiple dwelling buildings with single bathrooms, no laundry and no dishwashers

Number of Apartments	Valve Size
10-30	3/4"
31-60	1"
61-100	1-1/4"
101-180	1-1/2"
181-300	2"
301-500	2-1/2"
501+	Consult Paxton

Not sure what size to use? Feel free to reach out to us via email or phone. We'd be happy to size any project. See our apartment house sizing program on our website: www.paxtoncorp.com

Rough in Dimensions

Size	3/4"	1"	1-1/4"	1-1/2"	2"	2-1/2"
A	4-1/2"	4-1/2"	4-3/4"	5-1/8"	5-3/4"	7-1/8"
B	2-1/8"	2-1/8"	2-1/2"	2-5/8"	3-1/8"	3-1/2"
C	13-1/2"	13-1/2"	14-1/4"	14-3/4"	15-1/2"	15-3/4"

Dimensions are the same for the VM900 Actuator / TVS43R
Leave at least 4" clear on top of the actuator for cover removal

