

ELGE TECHNOLOGIES

NT Plate Heat Exchangers

Application:

Within the Elge product group, the NT series is a gasketed plate heat exchanger for multiple applications. Variety of materials that work across a broad range of liquids, temperatures and pressures. Well-suited for these liquid-to-liquid applications:

HVAC	chemical	sugar	marine
food	renewable energy	power	

Benefits:

Versatility—

- The right design, not a “good enough” design. A wide variety of materials, sizes, and plate configurations combine with sophisticated selection software to ensure a perfect selection, whatever your needs.
- The compact footprint allows you to use it in locations that you wouldn’t dream of with a shell-and-tube heat exchanger.

Higher Performance at a Lower Cost—

- Optiwave™ plate corrugations distribute the liquid evenly across the entire plate width, maximizing heat transfer and minimizing the number of plates (and cost) required.

Peace of Mind—

- Over 75 years of experience in crafting high performance plate heat exchangers.
- Independent performance certification to ASME and other standards.

Convenient Maintenance—

- PosLoc™ plate lead-ins cause the plate pack to self-align when re-installing.
- Ecoloc™ tools-free gaskets make gasket replacement a snap.
- Individual plates mean no heavy lifting tools are needed. Faster more efficient maintenance, with shorter down times.

Long Service Life—

- Careful corrugation design provides the ideal balance of high turbulence and proper fluid distribution, reducing fouling from less-than-perfect media.

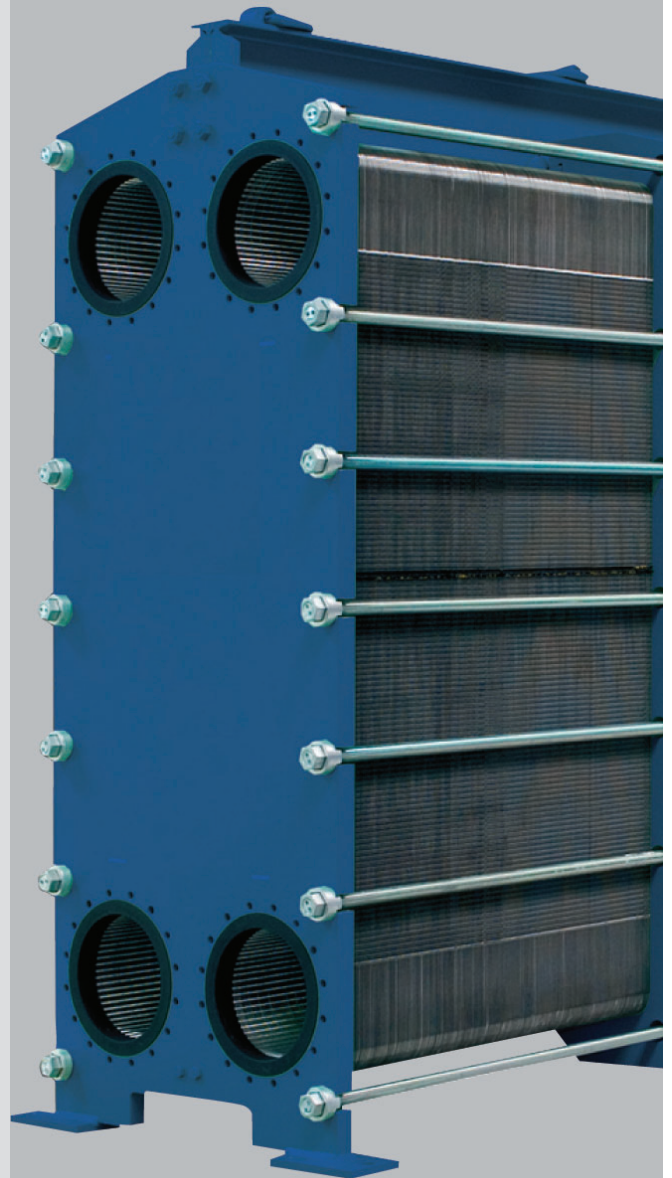

www.elge-technologies.com

Technical Details:

Heat Transfer Plate: 316 Stainless, 304 Stainless, Titanium, Hastelloy, 904L, SMO 254, and others on request.

Gasket: NBR, NBR High Temperature, EPDM, Viton, and others on request.

Pressure Plate: Carbon Steel, Stainless Steel, and others on request.

Port Connection: Unlined, Rubber Lined, Metal Lined (Stainless, Titanium and others on request), Welded Neck Flange, threaded nipple, and others on request.

Maximum Design Pressure: Maximum design pressure is 300 psig (21 bar). Depending on application.

Maximum Temperature: Maximum standard design temperature is 330°F (170°C). Higher temperatures are available on request.

Maximum Liquid Flow Rate:

- NT50: 175 gpm (40m³/hour)
- NT100: 830 gpm (190m³/hour)
- NT150: 1540 gpm (350m³/hour)
- NT250: 3960 gpm (900m³/hour)
- NT350: 8380 gpm (1900m³/hour)
- NT500: 20,000 gpm (4000m³/hour)

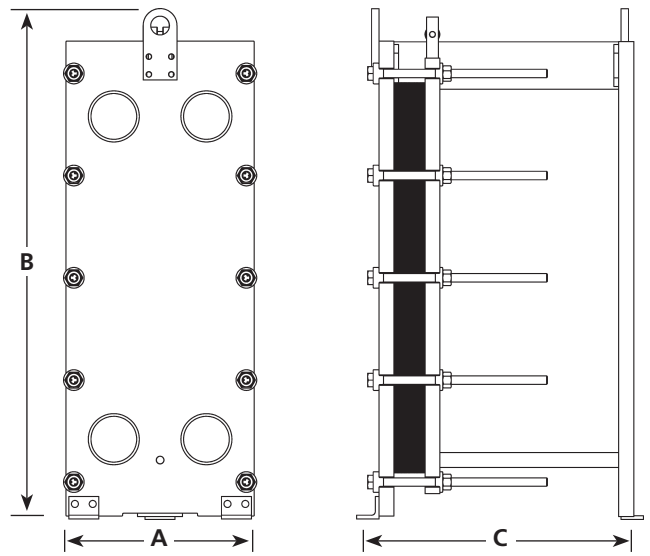

Model	Connection Size	Dim. A	Dim. B	Dim. C
NT 50 T	2" nominal (DN50)	12.7" (323mm)	26.6" (675mm)	Up to 44" (1120mm)
NT 50 M			40.4" (1025mm)	
NT 50 X			54.9" (1395mm)	
NT 100 T	4" nominal (DN100)	23.0" (584mm)	51.1" (1298mm)	Up to 158" (4013)
NT100 M			67.5" (1716mm)	
NT100 X			83.52" (2121mm)	
NT150 S	6" nominal (DN150)	26.2" (665mm)	70.1" (1781mm)	Up to 159" (4039mm)
NT150 L			89.4" (2271mm)	
NT250 S	10" nominal (DN250)	35.2" (895mm)	89.5" (2273mm)	Up to 159" (4039mm)
NT250 M			99.6" (2529mm)	
NT250 L			112.8" (2866mm)	
NT350 S	14" nominal (DN350)	44.7" (1134mm)	115.4" (2930mm)	Up to 238" (6045mm)
NT350 M			128.6" (3267mm)	
NT350 L			141.9" (3604mm)	
NT500 T	20" nominal (DN 500)	55" (1397mm)*	128" (3251mm)*	290" (7366mm)*
NT500 M			152" (3861mm)*	
NT500 X			176" (4470mm)*	

*Approximate, varies with design requirements.

Technical modification reserved. NT-USE 01/10 · Caskey

