

**ELGE®** SHELL & COIL HEAT EXCHANGERS

**INSTALLATION, OPERATION & MAINTENANCE MANUAL**

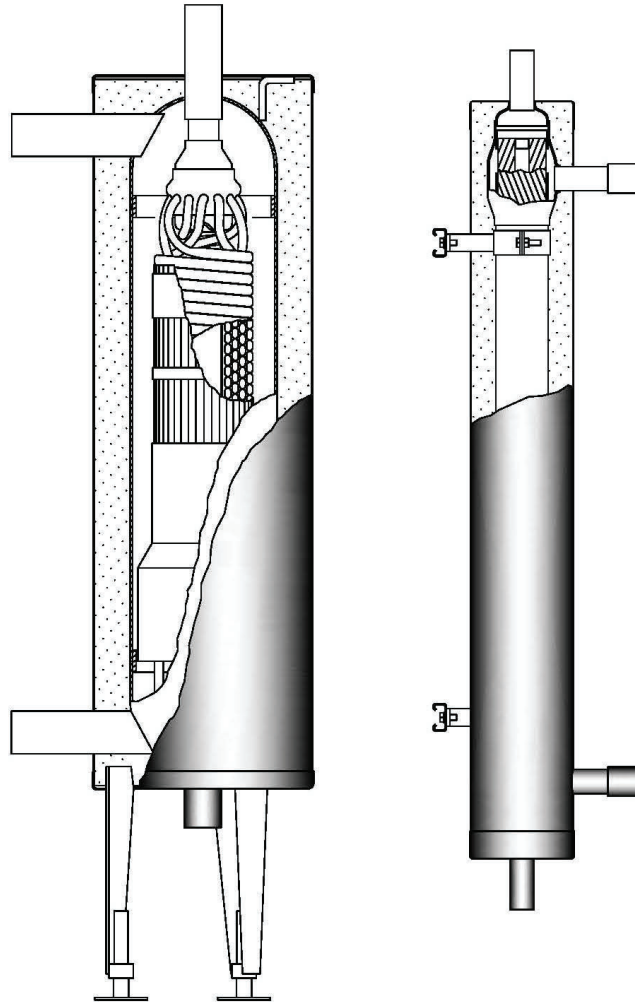

**ELGE MODEL:      MAC 2 MD 100-08**

## SEQUENCE OF OPERATION/START UP

### MAC MODULAR DOMESTIC HOT WATER HEATERS

Open all water valves

- HX supply
- HX return
- Recirculation line
- Mixing valves

Power up recirculation pump

- Confirm that flow is in the correct direction
- (Feeding Heat Exchanger and Mixing valve).

Confirm the HW mixing valve is in the lowest temperature setting.

Once water flow is established open steam valve slowly.

- Allow system to pressurize to the proper PSI.
- 5-10 psi is normal operating range for steam-water Elge systems.

Increase the HW mixing valve temperature:

- 120 degrees Fahrenheit is the standard setting for domestic hot water output.

Observe operation of system

- Record temperature returning to the HX
- Record temperature Leaving the HX
- After the mixing valve.

This should be done continuously for the first hour of operation.

The system should be checked for proper operation and temperature through the peak load period. Adjust as needed.

Domestic Hot water temperature leaving the mixing valve should not exceed 120 Degrees.

The system should be checked regularly through the day and temperatures should be recorded in a log book specific to that particular Heat Exchanger. If the system temperature rises above 120 degrees and not adjustable down to the working range the Heat Exchanger should be taken off line and isolated from the building system. A qualified technician should be called to troubleshoot the system.

# ELGE TECHNOLOGIES

## Capacity ELGE Shell & Coil HX

ELGE HX Type:	MDS 100-08
Number of Serial HX:	1
Number of Parallel HX:	2
Capacity: [1E+3 BTU/h]	1988
Temp Prim/Sec: [øF]	238.9 - 89.4 / 40.0 - 140.0
Steam Pressure: [Psi (g)]	9.9933
Media:	Steam / Water
Pressure Drop: [Psi]	/ 2.0
Flow Prim/Sec: [lb/h] / [GPM]	2086 / 40.00
Fouling: [1E-3 ft <sup>2</sup> hF/BTU, %]	0.568, 0
Oversize: [%]	153
Velocity Prim/Sec: [ft/s]	100.7 / 1.7

Innovative Heat Exchangers for the HVAC/R & Process Industries

## **1 FOREWORD**

This manual is a guide for installation; commissioning and maintenance of ELGE® shell & coil heat exchangers.

It is meant for those who are responsible for the installation, use and maintenance of the heat exchangers. We recommend that you read this manual carefully before commencing any work.

## **2 INTRODUCTION**

This manual is applicable for all ELGE® heat exchangers. Model A, AR, MD, MDS and CCD.

Elge Technologies LLC cannot be held responsible or liable for damage as a result of incorrect installation, use and/or maintenance of shell & coil heat exchangers as well as not complying with the instructions in this manual.

Please note that our shell & coil type heat exchangers are specially designed and built for the operating conditions (pressures, temperatures, capacities and type of fluids) provided by the customer. Sudden pressure peaks beyond the normal operating pressure (or pressure surges) which can occur during starting up or stopping of the system can severely damage the heat exchanger and should be prevented. Elge Technologies LLC cannot be held responsible for any damage as a result of any operation deviating from the original design conditions.

## **3 SAFETY ALERT NOTICES**

Refer to applicable SAFETY ALERT notices within the manual

All SAFETY ALERT notices are applicable to personal injury and identified by the following symbol.



**CONTENTS**

- 1 FOREWORD**
- 2 INTRODUCTION**
- 3 SAFETY ALERT NOTICES**
- 4 GENERAL**
  - 4.1 Identification of the heat exchanger
  - 4.2 Correct operation
  - 4.3 Precautions
- 5 CONSTRUCTION**
  - 5.1 Basics
  - 5.2 Types of ELGE® Heat Exchangers
- 6 INSTALLATION**
  - 6.1 Requirements to the installation area
  - 6.2 Standard installation requirements
- 7 OPERATION**
  - 7.1 Definition
  - 7.2 Start up and operation
  - 7.3 Shut-down
- 8 MAINTENANCE**
  - 8.1 Regular inspection
  - 8.2 Preventive Maintenance
  - 8.3 Determining Status of Heat Exchanger
  - 8.4 Cleaning
- 9 TRANSPORTATION & STORAGE**
  - 9.1 Transportation
  - 9.2 Storage
- 10 AFTER SALES SERVICE**
  - 10.1 Ordering parts

**WARRANTY CLAIM FORM**

## 4 GENERAL

### 4.1 Identification of the heat exchanger

All heat exchangers supplied are provided with a name plate. On this plate the following details are specified:

- Heat Exchanger Model
- Manufacturing Serial Number
- Max. working pressure in PSIG
- Test pressure in PSIG
- Max. working temperature in °F

### 4.2 Correct operation

**This user manual provides information and instructions for correct and safe operation of the unit. Many accidents can be caused by incorrect use!**

**It is essential that you study the instructions carefully, and above all, ensure the availability to those who install, maintain and operate the apparatus on a daily basis. This manual will be of no value if it is not available at the time when your staff needs it.**

Should you have a problem with your Elge Heat Exchanger which is beyond the scope of this manual, do not hesitate to contact us. The installation should not be put into operation before all open questions have been solved!

To avoid injuries and damages, follow the instructions and local applicable safety regulations. Also take the necessary protective measures, depending on the nature of your process or circumstances related to it, at your plant.

Please note that our heat exchangers are especially designed and built for the operating conditions (pressures, temperatures, capacities and type of fluids) provided by the customer. Sudden pressure peaks beyond the normal operating pressure (or pressure surges) which can occur during starting up or stopping of the system can severely damage the heat exchanger and should be prevented. Alstrom cannot be held responsible for any damage as a result of any operation deviating from the original design conditions.

If you wish to alter the design conditions, please contact us. You may only commission the heat exchanger under the modified conditions after inspection and written approval by Elge. Also the name plate on the heat exchanger will require modification and ASME (if applicable) will be notified.

### 4.3 Precautions

All potential personal injury hazards are identified by safety alert symbol.



Bodily harm can be caused by:

---

- Burning as a result of touching the heat exchanger or other parts of the installation.
- The uncontrolled release of pressurized media with which the danger of burning and other injuries is present.
- Contact with chemicals.
- Touching sharp edges of the installation.

Damage to equipment can be caused by:

- External forces.
- Corrosion.
- Chemical action.
- Erosion.
- Wear.
- Water hammer.
- Thermal and / or mechanical shock.
- Freezing.
- Incorrect transport / lifting.

Please note that even after shut down some parts can still be hot!

The heat exchanger may only be used with the fluids specified on the datasheet.

The hot medium may not flow through the heat exchanger without the cold medium flowing through. This is to prevent damage to the apparatus.

In case the cold medium is present but does not flow while the hot medium is flowing through, the cold medium will start boiling and the heat exchanger will be damaged.

Sudden pressure and temperature changes should be prevented.

---

## 5 CONSTRUCTION

### 5.1 Basics

The shell and coil heat exchanger consists of a tubes coil in a container called a shell. The fluid flowing inside the coils is called the coil side fluid and the fluid flowing on the outside of the coils is the shell side fluid. ELGE® Shell & Coil Heat Exchangers are designed for different environments such as water-water and steam-water. They are designed according to the counterflow principle for best thermal properties, at either full load or part load. The heating surface in ELGE® Shell and Coil Heat Exchangers is unique.

### 5.2 Types of ELGE® Heat Exchangers

Type: A/AR:

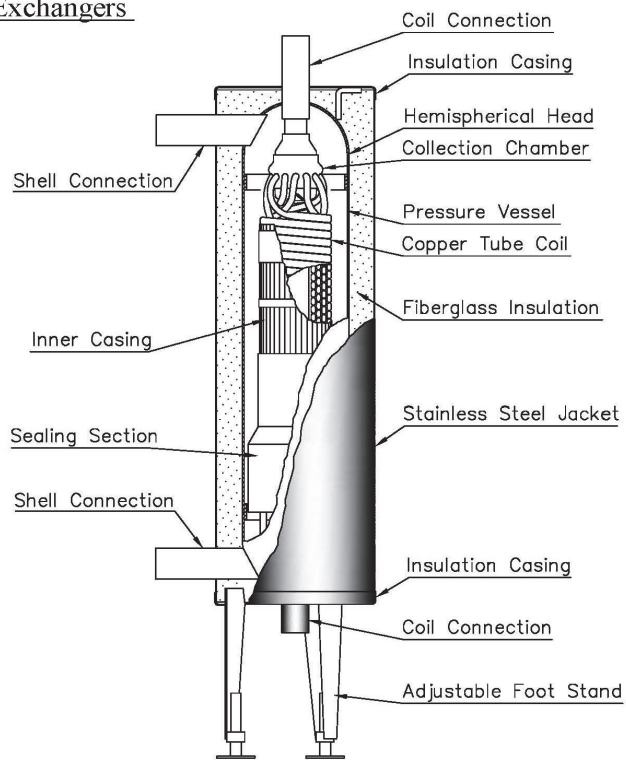

The heating surface in ELGE® Type A/AR Shell and Coil Heat Exchangers is unique. The copper tubes are coiled in layers with a spacer element in between. The tubes are given an oval cross section when coiled. The collection chamber, where the copper tubes open out, comprises a specially designed collection chamber for optimum flow. The connecting ends of the copper tubes, which are connected to the collection chamber, are round - this is to provide low inlet and outlet velocities.

## SHELL & COIL HEAT EXCHANGERS INSTALLATION, OPERATION & MAINTENANCE MANUAL

Type: MDR/MDS:

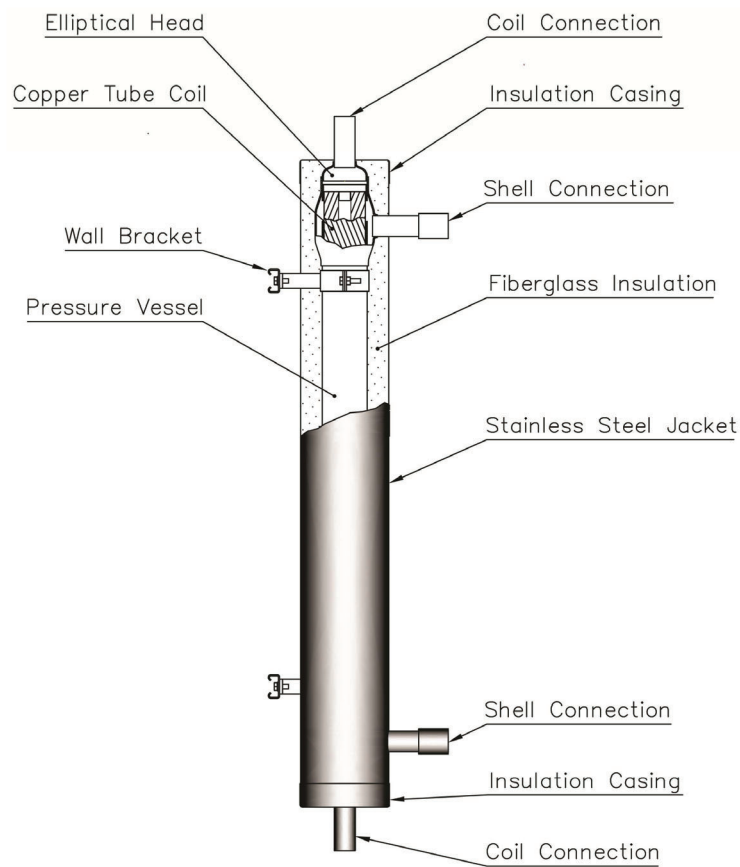

The spiral wound coil makes the heat exchangers very resistant to strains due to temperature and pressure fluctuations. The connecting ends of the copper tubes are modeled for simple and safe brazing. The heat exchanger is very compact thanks to optimal design of the pressure vessel. The small outside dimensions and the low total weight facilitate the handling of the heat exchangers.

## 6 INSTALLATION

### 6.1 Requirements to the Installation Area

It is very important that enough space around the heat exchanger is kept free for servicing of the unit(s).

Foundations must be adequate so that exchangers will not settle and cause piping strains. Foundation bolts should be set to allow for setting inaccuracies. In concrete footings, pipe sleeves at least one size larger than the bolt diameter slipped over the bolt and cast in place are best for this purpose, as they allow the bolt center to be adjusted after the foundation has set.

### 6.2 Standard Installation Requirements

Provide valves and by-passes in the piping system so that both the shell and coil sites may be by-passed to permit cutting out the unit for inspection or repairs.

Safety Device Connections are provided when required on shells. To safeguard against failures or possible ruptures during operation, the unit must be protected with a safety relief valve set at the proper pressure. In the coil circuit, such devices should be placed in the inlet piping between the nearest valve and the unit.

Provide thermometer wells and pressure gage connections in all piping to and from the unit, as near the unit as possible.

Provide necessary air vent cocks so that the unit can be purged to prevent or relieve vapor or gas binding of either the coil or the shell.

Loosen foundation bolts at one end of the unit to allow free expansion of shell. Oval holes in foundation brackets are provided for this purpose (if applicable).

Inspect all openings in the heat exchanger for foreign material. Remove all wooden plugs and shipping pads just before installing.

Set exchangers level and square so that pipe connections may be made without forcing.

Be sure entire system is clean before starting operation to prevent plugging of coil tubes or shell side passages with sand or refuse. The use of strainers or settling tanks in pipelines leading to the heat exchanger is recommended.

Provide thermometer wells and pressure gauge pipe taps in all piping to and from the heat exchanger, as close as possible to the unit for heat exchanger performance evaluation.

To guard against pulsation of the fluids caused by reciprocating pumps, compressors or other equipment a surge drum should be installed.

## 7 OPERATION

### 7.1 Definition

Operation Procedures must be strictly followed in start-up and shut-down sequences. Heat exchangers should not be subjected to abrupt temperature fluctuations. Hot fluid must not be introduced when the unit is cold, nor cold fluid introduced when the unit is hot.

### 7.2 Start Up & Operation

Commissioning may only be done by staff which has been trained specially for the job or by Elge authorized personnel.

Control, maintenance and repair of the installation may only be done by authorized, trained and properly instructed staff.

Maintenance may only be done with a shut down heat exchanger.

Check if all connections are fitted correctly.

Check the pressures and temperatures of the media and make sure that these are not more than the values specified on the identification plate.

**MANUFACTURER RECOMENDS INLET STRAINERS ON BOTH STEAM AND COLD WATER SUPPLY. HEAT EXCHANGER FAILURE DUE TO SOLID PARTICULATES IS EASY TO DETERMINE AND WILL VOID WARRANTY.**

Check system for cleanliness to avoid plugging of coil tubes and pass partitions with refuse. Protective screens or strainers in piping to the heat exchanger are recommended.

Vent valves should be opened before fluid is admitted to heat exchanger.

Check all flange bolting for tightness.

Start flow of fluids gradually, introducing colder fluid first. When system is completely filled and all air vented, close vent valves.

The heat exchanger should never be operated at pressures, temperatures and flows in excess of those specified on the nameplate and design specification sheet.

For heat exchangers used in steam service, provision must be made to drain accumulated condensate prior to start-up.

---

Be sure that all parts of the system are clean and in proper operating condition. An exchanger cannot perform properly unless all connected equipment is functioning properly; yet, the exchanger is frequently blamed for nonperformance when the actual trouble is elsewhere in the system.

Observe the following precautions to obtain maximum performance:

- Exchanger must be full of fluid in both shell and coil sides.
- Provide periodic venting if air tends to accumulate in system.
- Maintain rated flow of both mediums.
- Avoid excessive flow of cooling water in exchangers used as coolers. It is a frequent cause of coil tubes failure through erosion.

### 7.3 Shut-Down

Most heat exchangers may be shut-down by gradually reducing the flow of the hot medium and then the cold medium.

#### **THERMAL SHOCK**

**Extreme caution must be taken to avoid subjecting the heat exchanger to thermal shock, excessive pressures and temperatures. These conditions can impose stresses resulting in premature heat exchanger failure as well as other components in the system.**

**Under no circumstances should there be pulsating of fluids, as this causes vibrations that could damage the structural integrity of the heat exchanger. The system should be designed to prevent the unit from encountering pressure shocks and rapid temperature changes.**

## 8 MAINTENANCE

### 8.1 Regular Inspection

Typically, the failure of a heat exchanger to perform to specifications may be caused by one or more of the following factors: Excessive fouling, air or gas binding resulting from improper piping installation or lack of suitable vents, operating conditions differing from design conditions.

---

## 8.2 Preventive Maintenance

All modern, high efficiency heat exchangers have very small flow passages to increase heat transfer. Even though ELGE Shell & Coil Heat Exchangers are very resistant to fouling, installation of filters to eliminate particulate fouling is critical. Once a passage becomes partially blocked other types of more serious fouling will occur and the flow distribution through the heat exchanger is significantly compromised. Poor distribution means lower efficiency and poorer performance.

Failure to keep all tubes in coil clean can result in severe flow restrictions through some tubes which could cause damaging thermal stresses, resulting in leaking tube joints or structural damage to other components.

Temperatures and pressures of the fluid entering and leaving the equipment should be checked regularly to evaluate the function of the unit. For example, an increase in the pressure drop across the unit – with an accompanying decrease in the temperature range may indicate vapor or gas binding.

## 8.3 Determining Status of Heat Exchanger

At the time of initial installation, flow rate, pressure drop and temperatures entering and leaving the heat exchanger should all be noted. These will serve as a benchmark to determine if fouling is occurring. If there is a change in temperature or pressure drop, fouling will be the likely cause. Fouling insulates the heat exchanger surface decreasing performance and it restricts the channels causing an increase in the pressure drop.

**NOTE:** *Never wait until the heat exchanger is completely plugged before attempting cleaning. Even a partially plugged channel may restrict cleaning efforts to an extent which renders them ineffective.*

## 8.4 Cleaning

If cleaning is required, back flushing with water will remove most soft particulate matter. After back flushing, check your benchmark again to determine if fouling in the form of hard deposits may exist.

If fouling in the form of hard deposits is present, back flushing with a weak (5%) organic acid is recommended. This back flushing should last for 6 to 8 hours and the pH of the solution should be maintained. A higher flow rate will improve the effectiveness of the flushing process. However, the flow rate should not exceed 1.5 times the normal design conditions.

---

After flushing with acid, back flush and normal flush with large amounts of water to flush all acid from the heat exchanger before reactivating the system. After the chemical flush, pressure test the heat exchanger with water to test for any leaks.

Information on acid flushing may be obtained from chemical supply houses. There are also chemical cleaning companies which often will contract for periodic cleaning of heat exchangers. Special acid resistant pumps may be required depending on the solution used for flushing.

**CAUTION!**



- Be sure the acids you use are of such composition and strength that they are compatible with all components of the heat exchanger (material, brazing or solder, gaskets, shell etc.) as well as all system piping, fittings, pumps etc.
- The interaction of materials and acids can dramatically change with different concentrations. Use only concentrations recommended by qualified chemists.
- Acid flush only in a well vented space. Some gases may be produced which are poisonous or explosive. Ask your chemical consultant about potential hazards and precautions.
- The residue remaining after the system has been flushed may contain heavy metals and/or be acidic. Dispose of according to appropriate city, state and federal laws.

## 9 TRANSPORTATION & STORAGE

### 9.1 Transportation

During transportation of the heat exchangers, ensure that they are not exposed to mechanical damage. Upon receipt of the unit, inspect for shipping damages. Notify the carrier and Elge Technologies LLC immediately in the event damages do occur.

### 9.2 Storage

Heat exchangers should be stored in a clean, dry, low humidity area away from corrosive environments or weather elements (rain, snow etc.). If the unit is not to be placed in immediate service, appropriate precautions should be taken to prevent rusting and/or contamination. Heat exchangers that are out of service for extended periods of time should be protected against corrosion.

---

## **10 AFTER SALES SERVICE**

### **10.1 Ordering parts**

When ordering parts it is important that the correct details are given. At least the following should be quoted:

- Serial number
- Exchanger model
- Required parts

## SHELL & COIL HEAT EXCHANGERS WARRANTY CLAIM

To file a claim under the warranty, the purchaser must do the following during the warranty period:

Before returning the product to Elge Technologies LLC for warranty service, the purchaser must complete the Warranty Claim Form and fax it to 631-348-4800 or e-mail to [elgehx@gmail.com](mailto:elgehx@gmail.com). Upon preliminary assessment of the claim, Elge Technologies LLC will provide the purchaser with Return Merchandise Authorization Number. The RMA number must be clearly displayed and attached to the product on its return before it can be processed.

Proper packing of the product in the original container, or equivalent, is the responsibility of the purchaser. The warranty does not cover expenses or labor for disassembly, removal, shipment, reassembly or reinstallation; the purchaser will be responsible for such costs.

Elge Technologies LLC warrants the product against defects in materials and workmanship for a period of one (1) year from date of shipment/invoice. Should the product fail to perform according to the specifications set forth by Elge Technologies LLC during the warranty period, Elge will repair or replace, free of charge, the products that it finds defective.

If you wish to make a warranty claim, please complete this form. Incomplete forms will not be processed.

**Contact Name:** \_\_\_\_\_ **Company:** \_\_\_\_\_

**Address:** \_\_\_\_\_

**Phone:** \_\_\_\_\_ **Fax:** \_\_\_\_\_

**E-Mail:** \_\_\_\_\_

**PRODUCT INFORMATION:**

**Model:** \_\_\_\_\_ **Serial No:** \_\_\_\_\_

**Date of Shipment or Invoice:** \_\_\_\_\_

**EXPLANATION OF FAILURE/SYMPTOMS OF DEFECT:**

---

---

---

---

---

---

---

---

<p><b>FOR OFFICE USE ONLY</b></p> <p><b>Authorized by:</b> _____</p> <p><b>Signature:</b> _____ (PRINT)</p>	<p><b>RMA No:</b> _____</p> <p><b>Date:</b> _____</p>
---	---