

# Elge Technologies LLC

13 Central Drive, Glen Head, NY 11545  
273 Knickerbocker Ave, Bohemia, NY 11716  
Tel: 833-HEATEX1

## SUBMITTAL

DATE: 3/20/2025

Customer

*Platinum Energy Group*

PROJECT

Edenwald Houses

Building #	DESCRIPTION	Model
7,15, 17,18,28, 20, 29, 30	ELGE HIGH EFFICIENCY SHELL AND COIL HEAT EXCHANGER	SPU-A-51
	3" Electronic steam control valve with Control Panel	Paxton
	F & T Steam trap, strainer	Mepco
	Thermometer	Bluefin
	Safety Relief Valve	Watts
	Vacuum breaker	Barnes & Jones
8, 14, 22	ELGE HIGH EFFICIENCY SHELL AND COIL HEAT EXCHANGER	SPU-A-61
	3" Electronic steam control valve with Control Panel	Paxton
	F & T Steam trap, strainer	Mepco
	Thermometer	Bluefin
	Safety Relief Valve	Watts
	Vacuum breaker	Barnes & Jones



**ELGE®**  
*Shell and Coil Heat Exchanger*



[www.elge-technologies.com](http://www.elge-technologies.com)

# Elge Instantaneous Hot Water Heaters

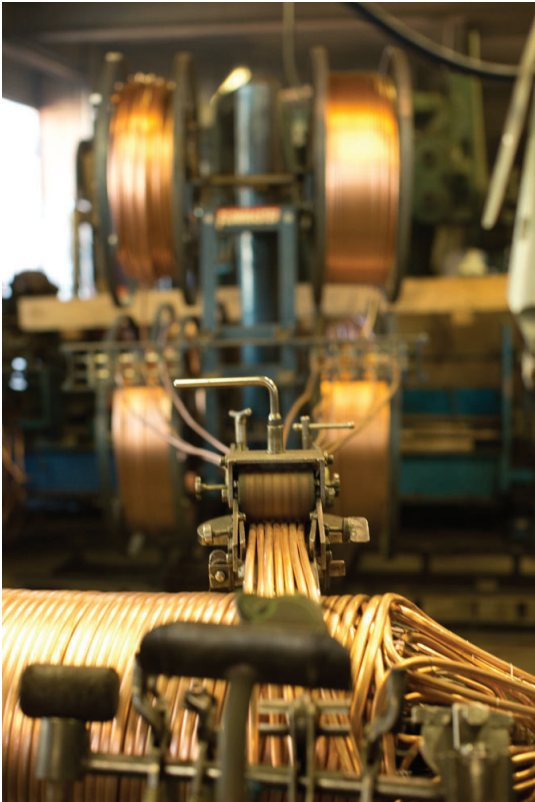

## Coil Design is Reliable, Self-Cleaning

ELGE®'s coil design eliminates stress at the connection points due to expansion and contraction. In addition, this movement causes the coil to be self-cleaning. Scale is automatically removed and can be easily flushed from the system through the flush valve on the bottom of the Steam Water Heater.

## Efficient and Economical

ELGE®'s Model A/AR Water Heater is efficient in both space and performance. Its vertical design requires less than 4 square feet. ELGE's use of proven components provides a reliable yet economical package.

## Eliminates Storage Tank Hazards

Expensive, space-hog storage tanks can be eliminated or their size minimized by using an instantaneous ELGE® Steam Water Heater.

Storage tanks are a breeding ground for corrosion-causing bacteria and hazardous bacteria such as legionella, etc. Stratified tanks can supply the ideal breeding temperature for any type of water borne bacteria.

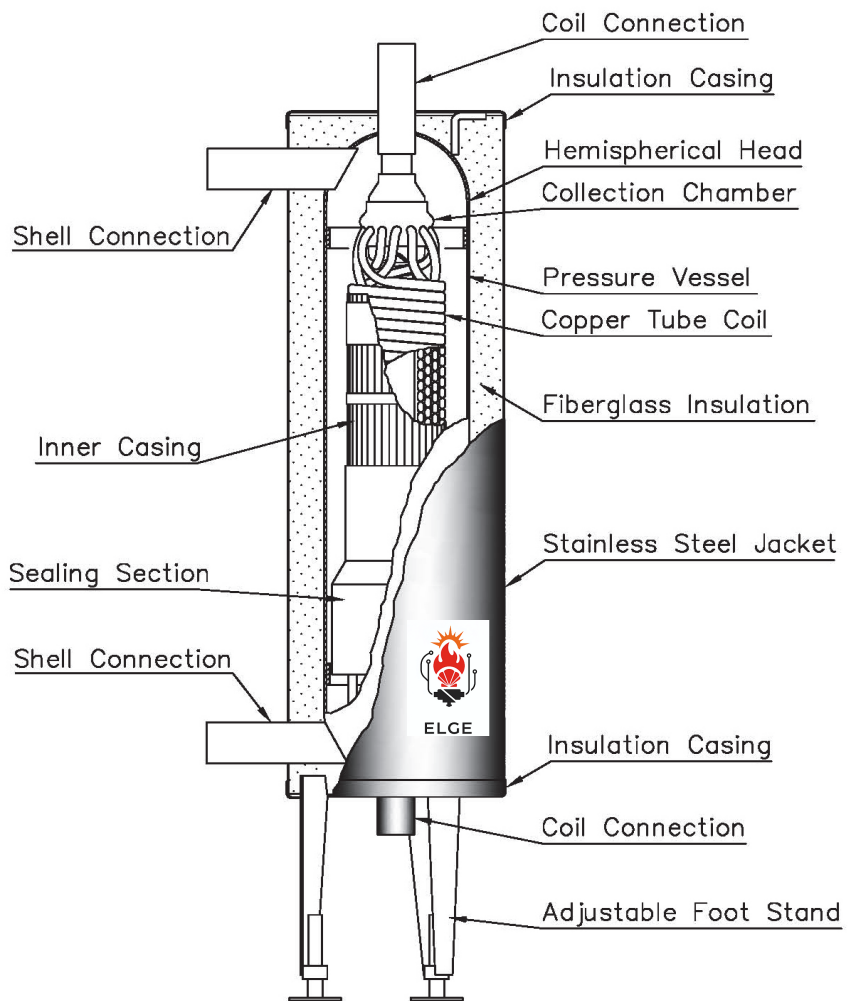

**APPROVED**

Company: \_\_\_\_\_  
 Approved by: \_\_\_\_\_  
 Name \_\_\_\_\_  
 Signature \_\_\_\_\_  
 Date: \_\_\_\_\_

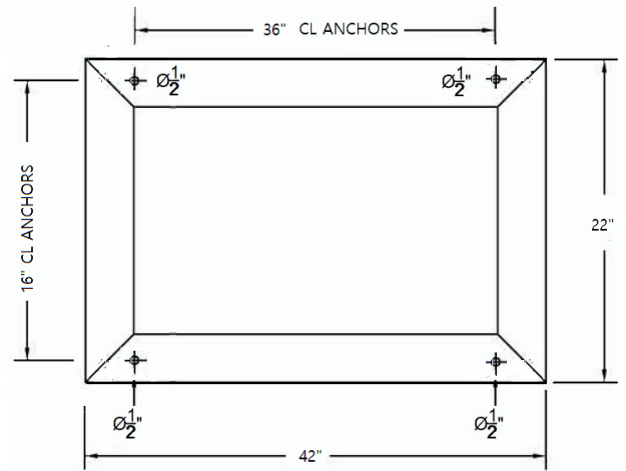
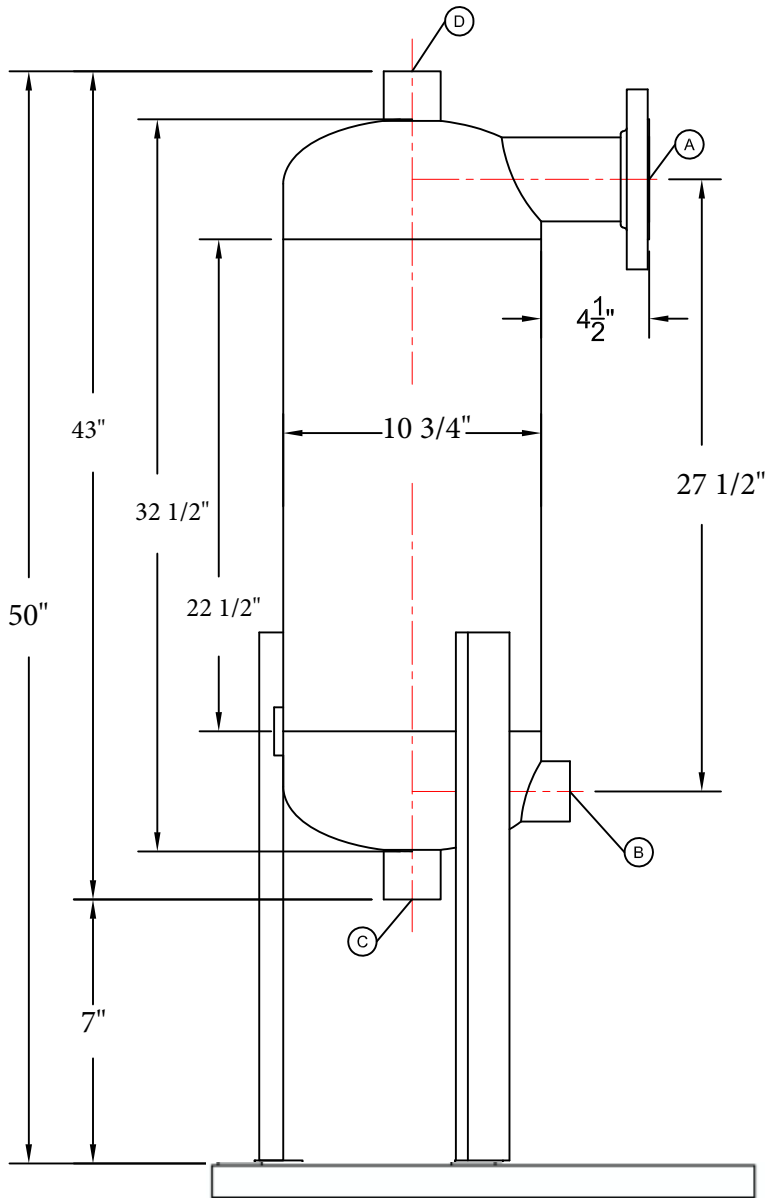

**BASE SUPPORT**

**DESIGN DATA**

LOCATION	PRESSURE, PSIG		TEMPERATURE, F°	
	DESIGN	TEST	DESIGN	TEST
SHELL	200	PER CODE	400	70

**NOZZLE**

	SIZE	SERVICE	DESCRIPTION
(A)	3"	STEAM INLET	150# RF.SO.
(B)	2"	CONDENSATE OUTLET	3000# NPT
(C)	2"	WATER INLET	PIPE STD
(D)	2"	WATER OUTLET	PIPE STD

**MATERIAL**

SHELL	SA 53 GR E/B
HEAD	SA 234 WPB
FLANGES	SA 105

**NOTES:**

- FABRICATED AND STAMPED IN ACCORDANCE WITH ASME CODE, SECTION VIII, LAST EDITION

DRAWN BY FS	
CHECK BY P.L.	
QUALITY CONTROL P.L.	



THIS DOCUMENT CONTAINS CONFIDENTIAL INFORMATION WHICH IS THE PROPERTY OF ELGE TECHNOLOGIES. THIS DOCUMENT MAY NOT BE REPRODUCED, TRANSFERRED OR USED, OR ITS CONTENTS DISCLOSED, WITHOUT THE WRITTEN PERMISSION OF THE OWNER.

**MODEL A-51**

SIZE A	SERIAL NO XXXXX	DWG NO. 51-GEN	REV 0
SCALE 1:8		SHEET #1	

**APPROVED**

Company: \_\_\_\_\_  
 Approved by: \_\_\_\_\_  
 Name \_\_\_\_\_  
 Signature \_\_\_\_\_  
 Date: \_\_\_\_\_

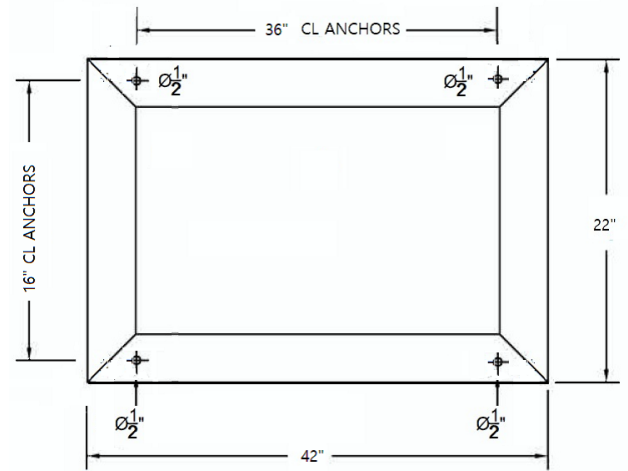
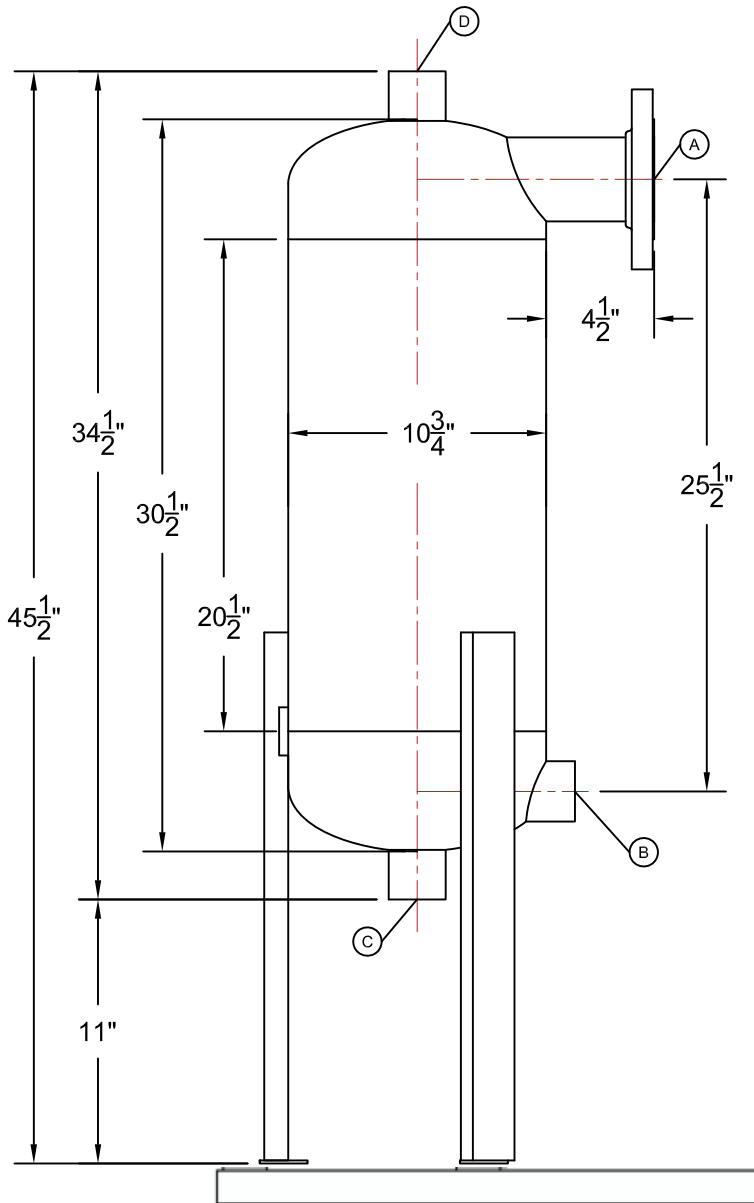

**BASE SUPPORT**

**DESIGN DATA**

LOCATION	PRESSURE, PSIG		TEMPERATURE, F°	
	DESIGN	TEST	DESIGN	TEST
SHELL	200	PER CODE	400	70

**NOZZLE**

	SIZE	SERVICE	DESCRIPTION
A	3"	STEAM INLET	150# RF.SO.
B	1-1/2"	CONDENSATE OUTLET	3000# NPT
C	2"	WATER INLET	PIPE STD
D	2"	WATER OUTLET	PIPE STD

**MATERIAL**

SHELL	SA 53 GR E/B
HEAD	SA 234 WPB
FLANGES	SA 105

**NOTES:**

- FABRICATED AND STAMPED IN ACCORDANCE WITH ASME CODE, SECTION VIII, LAST EDITION

DRAWN BY	<b>RS</b>
CHECKED BY:	<b>DP</b>
QUALITY CONTROL	P.L.

**ELGE®**  
 Shell and Coil Heat Exchanger

THIS DOCUMENT CONTAINS CONFIDENTIAL INFORMATION WHICH IS THE PROPERTY OF ELGE TECHNOLOGIES THIS DOCUMENT MAY NOT BE REPRODUCED, TRANSFERRED OR USED, OR ITS CONTENTS DISCLOSED, WITHOUT THE WRITTEN PERMISSION OF THE OWNER.

**A-61**  
 GENERAL

CUSTOMER/JOB NAME:	<b>STANDARD/ ROCKINGHAM COUNTY</b>
--------------------	--

SIZE	SERIAL NO	DWG NO.	REV
A		A-61	0
SCALE	SHEET #1		
1:8			



# Shell and Coil Heat Exchanger

## ELGE® “A” Style Heat Exchanger For Domestic Hot Water STEAM TO WATER SIZING CHART Low Pressure Steam

Model	GPM Steam Pressure			lb/h Steam Pressure			BTU Steam Pressure		
	5	10	15	5	10	15	5	10	15
A11	9	10	11	466	522	578	450,000	500,000	550,000
A21	12	13	14	621	678	736	600,000	650,000	700,000
A31	15	17	19	776	887	998	750,000	850,000	950,000
A41	23	25	27	1190	1304	1419	1,150,000	1,250,000	1,350,000
A51	32	36	39	1655	1878	2049	1,600,000	1,800,000	1,950,000
A61	42	45	48	2172	2347	2522	2,100,000	2,250,000	2,400,000
A71	57	60	65	2946	3130	3416	2,850,000	3,000,000	3,250,000
A81	65	68	73	3362	3547	3836	3,250,000	3,400,000	3,650,000

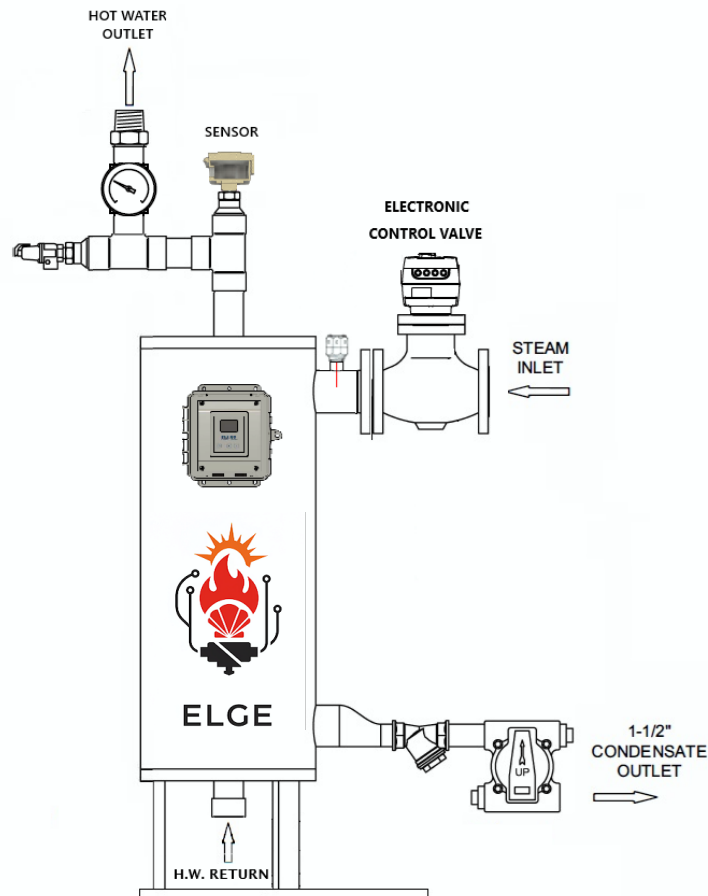

ELGE PACKAGED UNIT PIPING & CONTROLS



# Shell and Coil Heat Exchanger

## ELGE® Shell & Coil Heat Exchangers Type A Steam to Water Dimensions

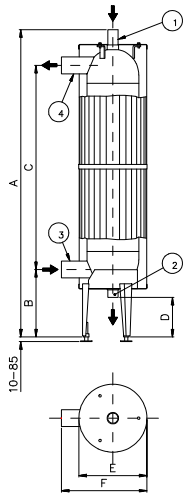

**HEATING**

1. Steam Supply
2. Condensate Return
3. Heating Return
4. Heating Supply

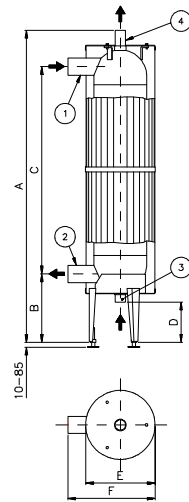

**DOMESTIC HOT WATER**

1. Steam Supply
2. Condensate Return
3. Cold Water
4. Domestic Hot Water

Type	A	B	C	D	E	F	Weight lb	Connections Heating		Connections DHW		Volume US Gal.					
								1	2	3	4	1	2	3	4	Shell	Coil
								inch		inch		inch		inch			
A-11/A-21	43.5	11.0	26.7	7.7	10.0	17.7	77/88	1 1/4	2	2	1 1/4	2.6/2.4	0.8/0.8				
A-31/A-41	45.5	11.3	27.8	8.5	11.6	19.2	110/121	1 1/2	2 1/2	2 1/2	1 1/2	4.7/4.0	1.0/1.6				
<b>A-51/A-61</b>	<b>49.6</b>	<b>14.0</b>	<b>28.2</b>	<b>9.2</b>	<b>14.1</b>	<b>21.8</b>	176/198	2	3	<b>3</b>	<b>2</b>	<b>8.7/7.7</b>	<b>2.4/2.9</b>				
A-71/A-81	54.4	14.4	31.8	9.7	16.9	25.5	309/331	2 1/2	4	4	2 1/2	15.6/14.5	3.7/4.7				



**ELGE**

## Elge Instantaneous Hot Water Heaters—Why they work best

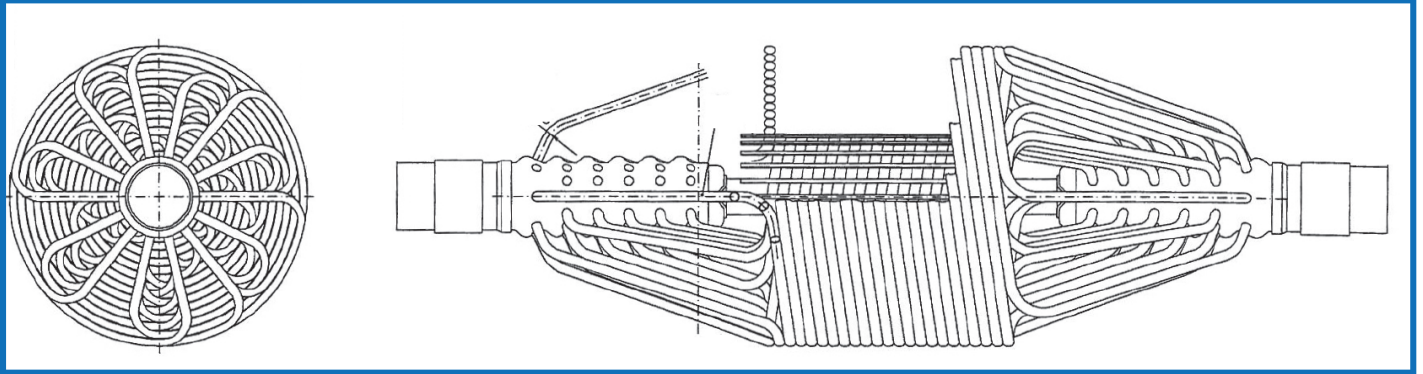

**Even, Controlled Flow:** When the copper is coiled, it is molded to a oval shape to yield a larger heat transfer area and spacers are inserted between the rows. Hot water or steam enters the head and is diverted through the coil bundle in a counter/cross-flow manner. The inner casing ensures even and controlled flow over the exterior of the tubes in the bundle.

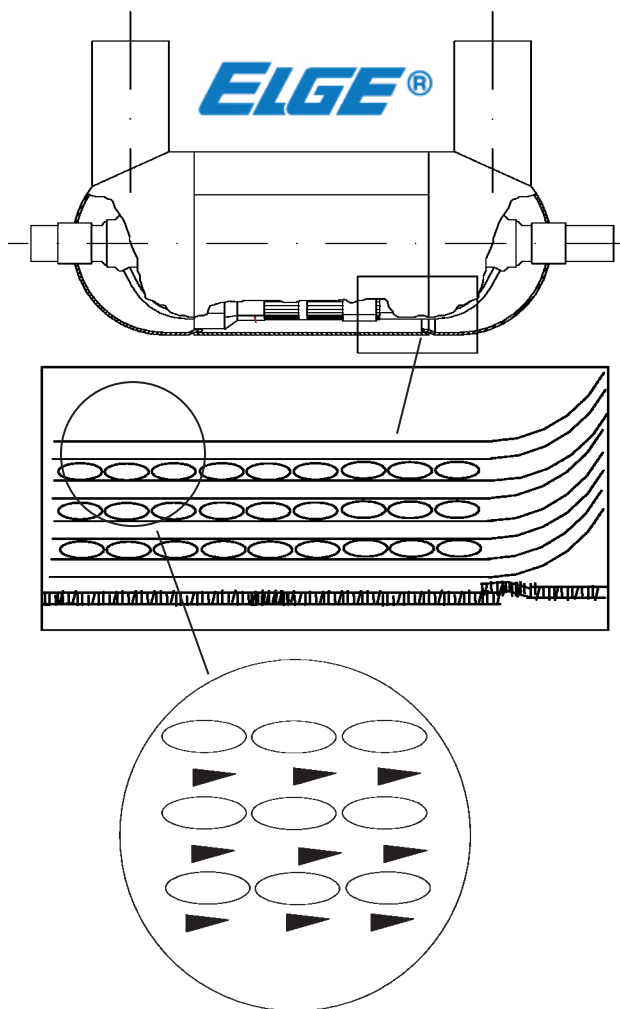

### **Efficient and Precise:**

The design of the collection chamber, and the angle of the tubes results in a low flow rate and less resistance where the water enters the tube. This means less erosion. However, as the tube changes from round to oval, there is a 50% increase in flow rate at the point of heat exchange.

### **Designed to Last**

The connection of the tubes to the chamber and of the coil to the head provide a large, strong silver solder area (15% silver used Cu-Cu and 45% used Cu-Steel). The coil design allows expansion and contraction to occur in the coil and minimizes any stress at these connective points.

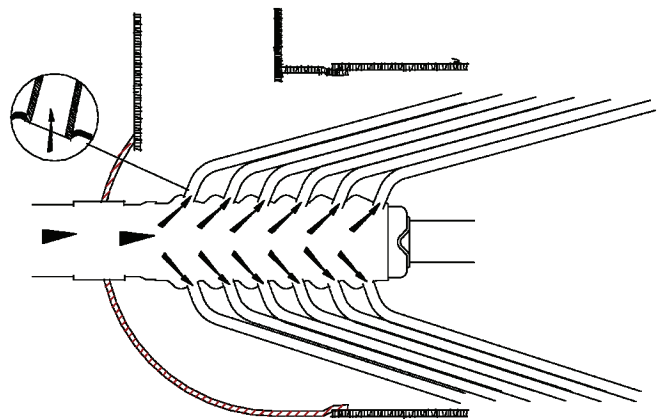

# *Elge Flow-Through Design*



V2B Series are 2-way valves with bronze trim and a 125 lb. rating used to control the flow of hot water, cold water, steam, and other noncorrosive fluids. These valves are fitted with electric or pneumatic actuators.

V2A use the same valve body as the V2B series but with stainless steel trim. V2C series valves have 250 lb. flanged bodies and bronze trim. V2D series valve have 250 lb. bodies and stainless steel trim.

### Technical Data

Size	2-½" to 6"
Connection	Series B & A - 125# ANSI flange Series C & D - 250# ANSI flange
Pattern	2-way
Fluid	Chilled or hot water, non-corrosive fluids
Pressure rating	125# Flange - Series B & A Up to 175 PSI below 150°F Up to 150 PSI below 250°F
	250# Flange - Series C & D Up to 400 PSI below 150°F Up to 265 PSI below 375°F
Flow characteristic	Equal percentage
Servicing	Replacement packing kit
Leakage rate	ANSI class III

### Materials

Valve body	Cast iron
Valve stem	Stainless steel
Valve trim	Series B & C - Bronze Series A & D - Stainless steel
Seal	PTFE

**Selection - 125# Flange****SERIES B**

Model	Size	Cv	Trim	Connection
V2B-065	2-½"	65	Bronze	ANSI 125#
V2B-080	3"	90	Bronze	ANSI 125#
V2B-100	4"	170	Bronze	ANSI 125#
V2B-125	5"	280	Bronze	ANSI 125#
V2B-150	6"	360	Bronze	ANSI 125#

**SERIES A**

Model	Size	Cv	Trim	Connection
V2A-065	2-½"	65	Stainless steel	ANSI 125#
V2A-080	3"	90	Stainless steel	ANSI 125#
V2A-100	4"	170	Stainless steel	ANSI 125#
V2A-125	5"	280	Stainless steel	ANSI 125#
V2A-150	6"	360	Stainless steel	ANSI 125#

**Selection - 250# Flange****SERIES C**

Model	Size	Cv	Trim	Connection
V2C-065	2-½"	65	Bronze	ANSI 250#
V2C-080	3"	90	Bronze	ANSI 250#
V2C-100	4"	170	Bronze	ANSI 250#
V2C-125	5"	280	Bronze	ANSI 250#
V2C-150	6"	360	Bronze	ANSI 250#

**SERIES D**

Model	Size	Cv	Trim	Connection
V2D-065	2-½"	65	Stainless steel	ANSI 250#
V2D-080	3"	90	Stainless steel	ANSI 250#
V2D-100	4"	170	Stainless steel	ANSI 250#
V2D-125	5"	280	Stainless steel	ANSI 250#
V2D-150	6"	360	Stainless steel	ANSI 250#

## Suitable Electric Actuators

Non-spring return	AME-655, AME-685, VM5000E
Spring return	AME-658
Electronic fail safe	AME-685 w/ VMS-50

Consult Paxton for pneumatic actuator options.

## Installation

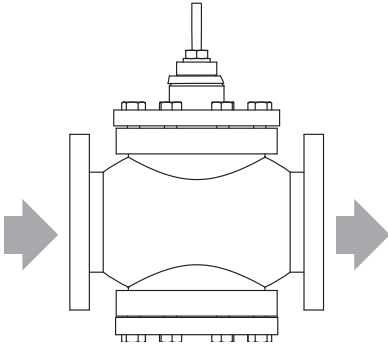

**Flow direction:** Pipe the valve so that the arrow tag on the valve body is in the direction of the flow. Do not install backwards.

As the stem travels down, the valve closes. As the stem travels up the valve opens.

*Note: on special order, this can be reversed.*

## Dimensions - 125#

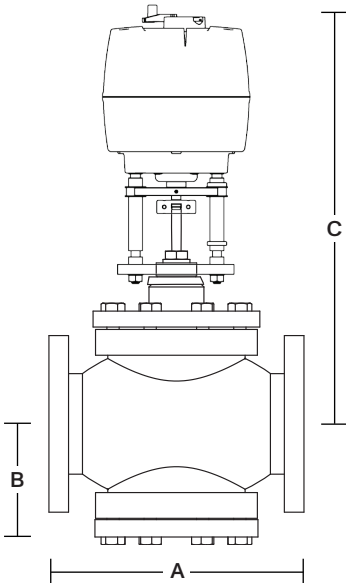

## SERIES B & A

	2-1/2"	3"	4"	5"	6"
A	9"	10"	13"	15-3/4"	17-3/4"
B	4-3/4"	5-3/8"	6-3/8"	5-3/4"	6-1/2"
C	18"	18-7/8"	19-7/8"	18-7/8"	19"
-AME-655 -AME-685 Sx					
C	23-1/2"	24-1/2"	25-1/2"	24-1/2"	24-7/8"
-AME-685					
C	20-3/8"	21-1/4"	22-1/4"	22-1/8"	23-7/8"
-VM5000E					
Weight	55	72	119	134	175

## Dimensions - 250#

## SERIES C & D

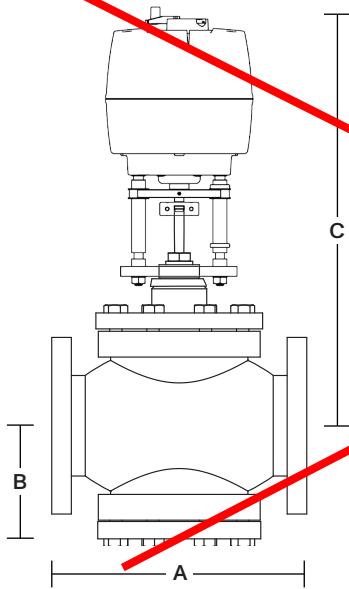

	2-½"	3"	4"	5"	6"
A	9-5/8"	10-3/4"	13-5/8"	16-5/8"	18-5/8"
B	4-3/4"	5-3/8"	6-7/8"	5-3/4"	6-1/2"
C -AME-655 -AME-685 Sx	18"	18-7/8"	19-7/8"	18-7/8"	19"
C -AME-685	23-1/4"	24-1/2"	25-1/2"	24-1/2"	24-7/8"
C -VM5000E	20-3/8"	21-1/4"	22-1/4"	22-1/8"	23-7/8"
Weight	64	77	131	166	233

## Close-Off Pressures

### In PSI

Actuator	AME-655	AME-685	VM5000E	AME-658 SU	AME-658 SD
Fail	In place	In place	In place	Spring, stem up	Spring, stem down
2-½"	71	175	175	71	71
3"	47	142	142	47	47
4"	20	77	77	20	20
5"	x	48	48	x	x
6"	x	32	32	x	x

If pressure close off listing is not shown, do not use this combination.

If higher close off and fail safe is required, use AME-685 with VMS-50 battery back up.

See also V22 Series and V23 Series valves for higher close off pressures.

## AME650 Series Actuators

### Description

AME650 Series actuators are designed for use with globe valves. They are offered in fail in place and fail safe options. The fail safe actuators feature a true spring return feature.

Linkage kits available to adapt to Paxton valves as well as valves by other manufactures.

All AME650 series actuators can be controlled with electronic controllers outputting 0-10V, 4-20mA, 3-point floating, or on/off control signals.

These actuators are designed for commercial and industrial use.



### Features

- Manual override
- Position indication
- Fail safe stem up or down options
- Automatic stroke calibration
- Valve characterization optimization
- Stroke limitation
- Thermal and electrical overload protection

### Ordering Data

Model Number	Fail Position
AME 655	In Place
AME658 SU	Fail Stem Up
AME658 SD	Fail Stem Down

### Technical Data

Model	AME655	AME658 SU	AME658 SD
Power Supply	24VAC / 24VDC (optional 120VAC 220VAC)		
Power Consumption	15 VA	20 VA	
Frequency	50/60 Hz		
Control Input	0-10V, 2-10V, 4-20mA, 0-20mA, 3-point floating		
Control Output	0-10V, 2-10V, 4-20mA, 0-20mA		
Force	450 lb / 2000N		
Max Stroke	2 inches / 50mm		
Speed	3 or 6 s/mm	4 or 6 s/mm	
Medium Temperature	Up to 392°F / 200°C		
Ambient Temperature	32°F to 131°F / 0°C to 55°C		
Weight	12 lbs / 5.3 kg	19 lbs / 8.6 kg	
Fail Mode	In place	Spring, Stem Up	Spring, Stem Down

## Installation

The actuator can be installed in any orientation. Verify with the valve manufacture before mounting the valve and actuator together.

## Wiring Diagrams

### Modulating

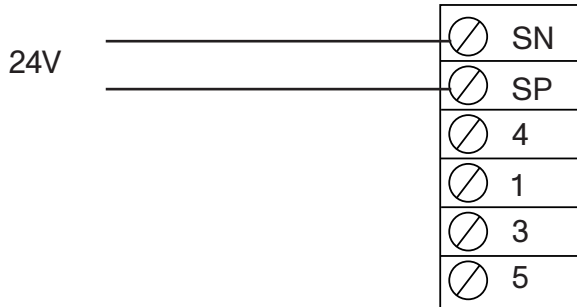

### Controller

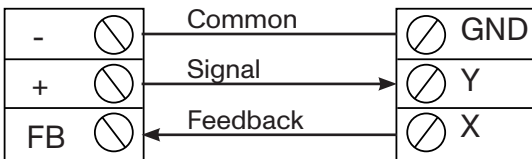

### Floating

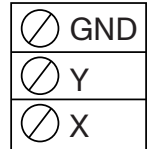
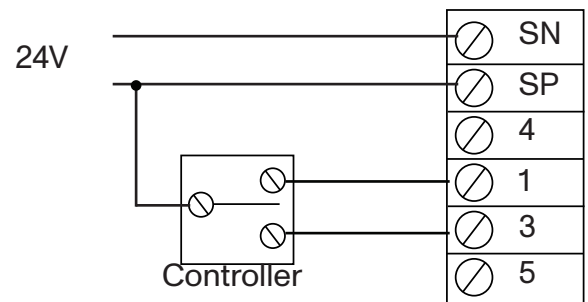

## Dimensions

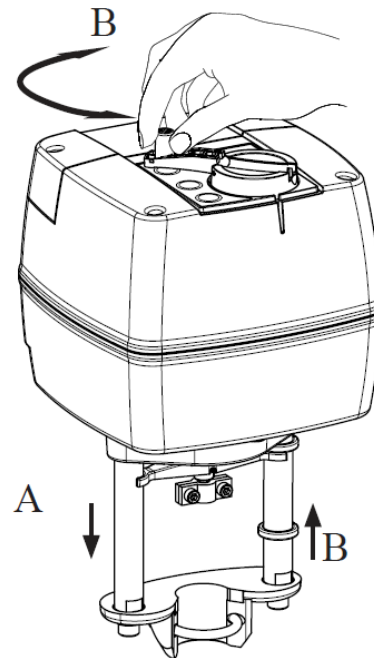
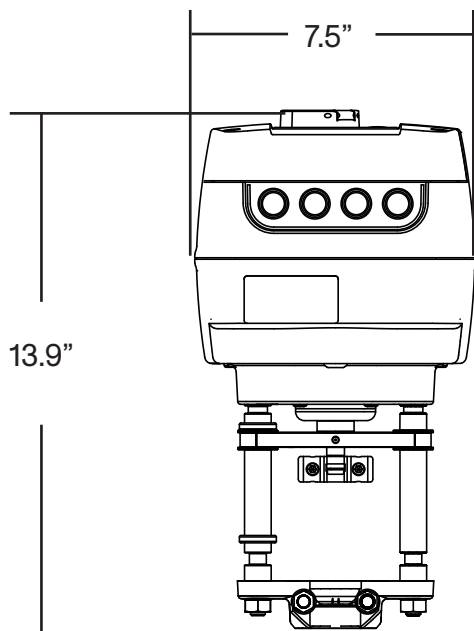

### Mechanical manual operation







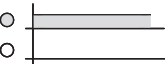

Actuators have a knob & crank on the top of the housing which enables manual positioning of the actuator.

Use Mechanical manual operation only when the power is disconnected.

## Operating Modes

### LED Operating Mode indicator

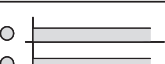
The three color LED, (green/yellow/red) are shown on the top of the actuator. They indicate the different operating modes shown below in the chart.

LED	Indication type		Operating mode
Green		Constantly lit	Positioning mode - Actuator is retracting the stem
		Constantly lit	Positioning mode - Actuator is extracting the stem
		Flashing (1 s cycle)	Self stroking mode - Actuator is retracting the stem
		Flashing (1 s cycle)	Self stroking mode - Actuator is extracting the stem
Yellow		Constantly lit	Stationary mode - Actuator has reached upper end position (retracted stem)
		Constantly lit	Stationary mode - Actuator has reached bottom end position (extracted stem)
		Flashing	Stationary mode - Y present (Only when input signal Y is set to voltage (V) ; DIP 7- position Uy)
Red		Constantly lit	Stand-By mode
		Flashing	Error Mode
Dark	No indication		No power supply

### Self Stroking Mode

Self stroking mode also known as actuator calibration mode starts automatically the first time the power is supplied to the actuator. To force the actuator into self stroking mode, press and hold the reset button for 5 seconds until the green light starts flashing. The actuator will stroke to the end positions of the valve and then return to stationary mode where it will respond to the control signal.

### Stand-By Mode

Press the reset button for 1 second. The actuator will stop in the current position and will not respond to the control signal. Once in standby mode, the actuator can be manually operated by rotating the adjustment knob on top by hand or by pushing the control buttons on the top of the actuator. To exit standby mode, press the reset button again.

### Positioning Mode

The actuator is operating automatically and is responding to the control signal.

### Stationary Mode

The actuator is operating without errors.

### Error Mode

Working temperature is too high or the valve stroke is too short. Make sure the valve is free from blockages.

## DIP Switch Settings

The actuator has a series of DIP switches (Fig. 1) under the service over that change the actuators parameters. The actuator ships with all of the DIP switches OFF.

### DIP 1: Fast/ Slow

ON: Slow 6 s/mm  
OFF: Fast 3 or 4 s/mm

### DIP 2: Direct or inverse action (Fig 2)

ON: Inverse action (i.e. 10V is stem down)  
OFF: Direct action

### DIP 3: Input Selection

ON: 0-10VDC or 0-20mA  
OFF: 2-10VDC or 4-20mA

Note: Both input an feedback are effected by this

### DIP 4: Characteristic Modification

ON: MFD position - enables modified correlation between Y input signal and stem position. The degree of modification depends on the position of the CM potentiometer. (FIG. 3)

OFF: LIN position - Linear correlation to Y signal and stem

Note: This function allows the operator to change the characteristics of the control valve. This feature does not impact other DIP switch settings

### DIP 5: Stroke Limitation

ON: 95% Limitation. Stroke is limited to 95%  
OFF: 100% stroke, no limitation.

### DIP 6: C/P Output Mode Selector

An output signal is present on terminal 4 when the position of the actuator is equal to or lower than the S4 set point. An output signal is present on terminal 5 when the position of the actuator is equal to or lower than the S5 set point.

C: position C provides a constant output signal on terminals 4 or 5, regardless of the input signal.

P: position P provides a pulse signal through parallel or cascade electrical wiring input 1 and 3 depends from the controller to output terminals 4 and 5.

### DIP 7: Smart Function Selector

ON: actuator enables special anti oscillation algorithm – see section on anti oscillation algorithm  
OFF the actuator does not try to detect oscillations in the system.

### DIP 8: Input signal type selector

Uy: input signal Y is set to voltage (V)  
ly: input signal Y is set to current (mA)

### DIP 9: Output signal type selector

Uy: input signal Y is set to voltage (V)  
ly: input signal Y is set to current (mA)

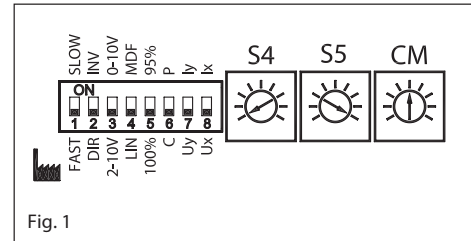

Fig. 1

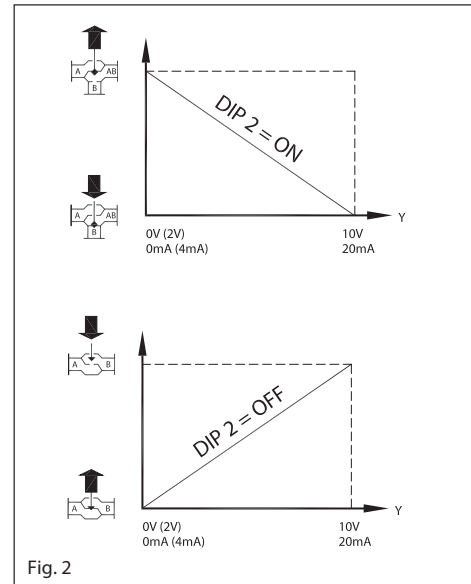

Fig. 2

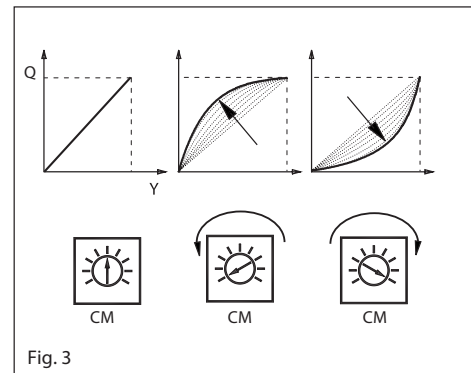

Fig. 3

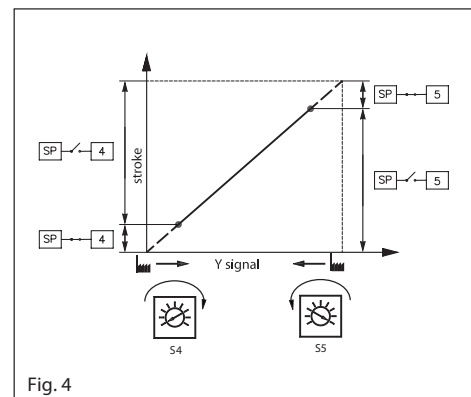

Fig. 4



For use with V2 Series Steam Control Valve



---

## Physical Install

---

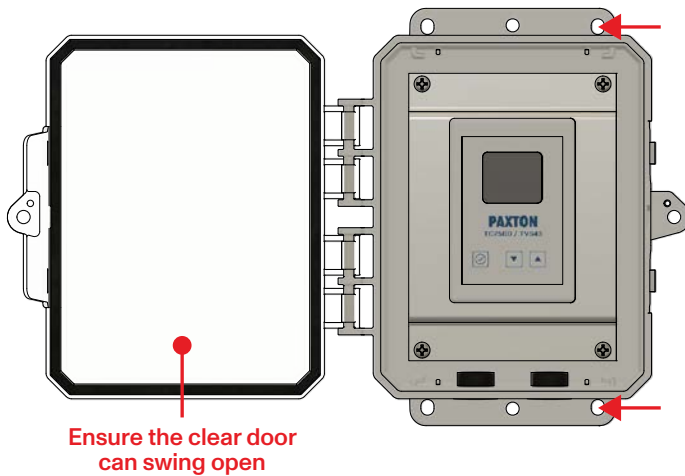

### Controller

Mount the enclosure of the controller security to wall or strut structure using the holes in the mounting flange of the controller.

Make sure the control is level, mounted at a reasonable height for programming.

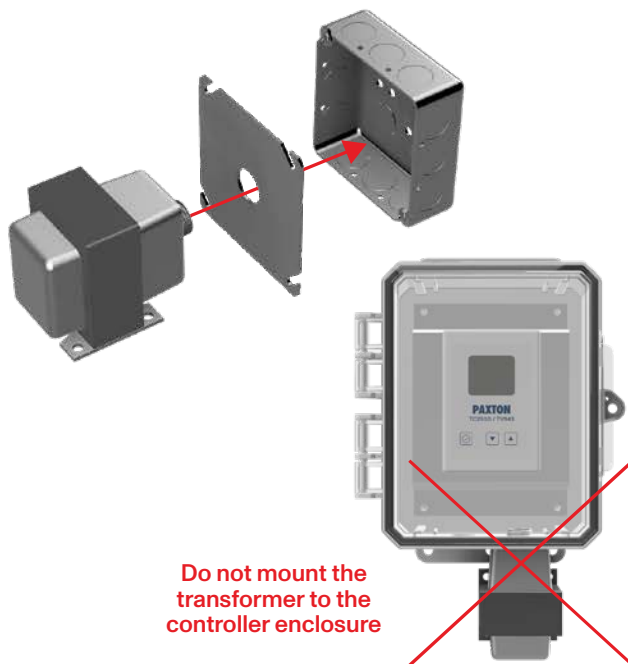

### Transformer

Mount the transformer to the included mounting plate and junction box.

Mount to wall close to control.

Line voltage side of transformer should be wired to a disconnect such as a breaker or switch.

**DO NOT MOUNT THE TRANSFORMER TO THE CONTROLLER ENCLOSURE.**

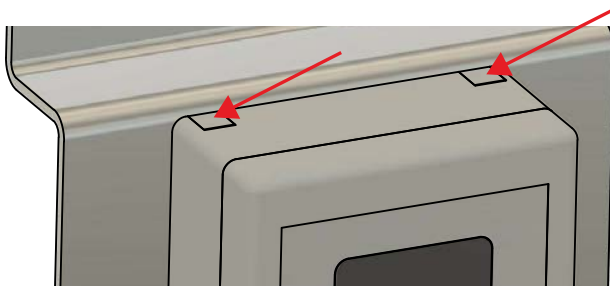

### Control Cover

Depress the two tabs on the controller and gently pull the faceplate off. This will expose the terminals. Poke holes in the bottom gray grommet to bring the wires through there or the back of the controller.

---

## Physical Install

---

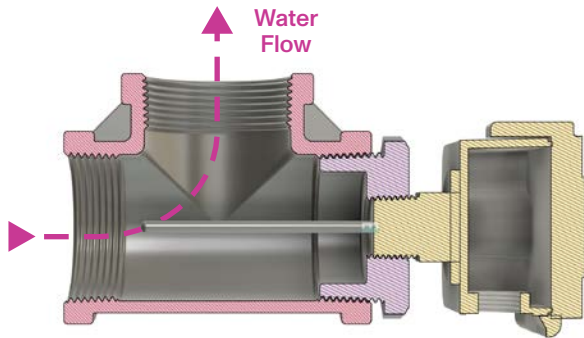

### Sensor

The STI series sensor has a ½" NPT connection and is to be installed directly into the water flow. DO NOT use an additional thermowell unless one is specifically provided by the factory. The STI series sensors are not compatible with thermowells. The temperature measurement will be incorrect.

It is vital to mount the sensor in the water flow. ¾" to 2" systems feature a 3 ½" long probe sensor, 2 ½" and 3" feature a 5 ½" sensor.

Mount the sensor in a tee or a heel tee in the outlet of the system piping.



Acceptable mounting positions

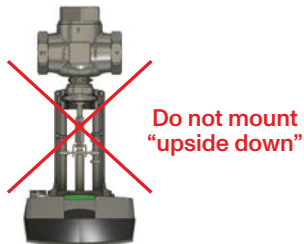

### Valve and Actuator

The valve and actuator should be mounted vertically in the system piping as shown in the piping diagram.

It is OK to mount the valve horizontally but vertical is preferred. Do not mount the valve where the actuator is below the valve "upside down".

It is best practice to mount the valve and actuator at "eye level" close to the controller. Leave at least 4" clearance about the actuator cover for service.

Ensure the valve and actuator are mounted far enough from the wall for actuator removal. Make sure the actuator is mounted straight onto the valve and that the u-bolt is tight.

---

### Wiring Control

Only remove or install the ribbon cable behind the controller cover with **power off**.

Do not hot plug (power on) the ribbon cable.

# Wiring Diagram

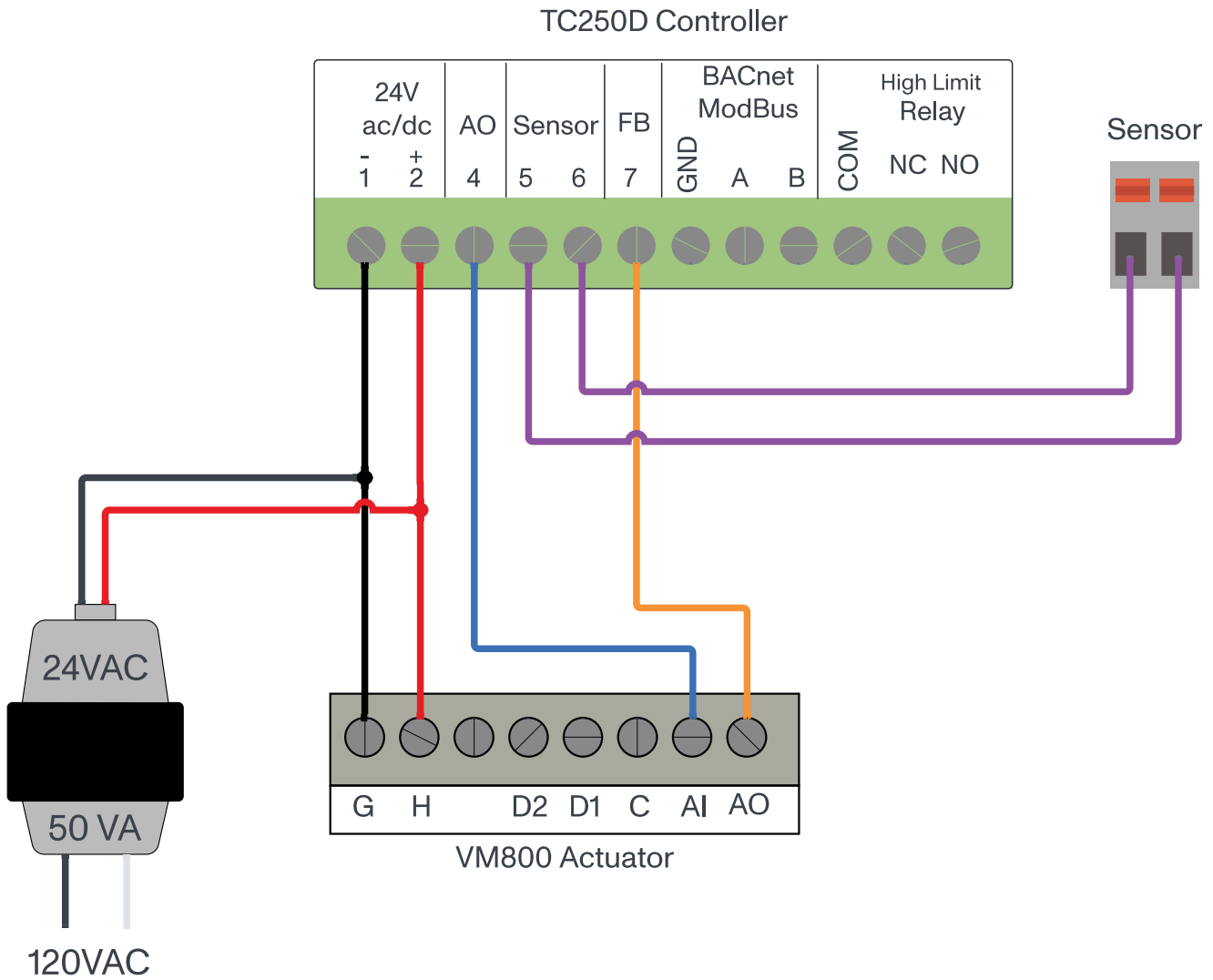

- Wire lengths should not exceed 200'.
- Use 18 gauge shielded wire.
- Run all low voltage and sensor wires in separate conduit from 120VAC circuits.
- The common from the control signal is shared with the neutral side of the transformer. Ensure that the H terminal on the actuator is shared with the 2 (+) terminal on the TC250D control and that the G terminal is shared with the 1 (-) terminal
- The control and actuator must share the same class II transformer.
- All DIP switches in the actuator should be OFF (factory setting).
- See actuator calibration in the commissioning section.
- Check transformer label for hot and common wire designation.

---

## How to Change Settings

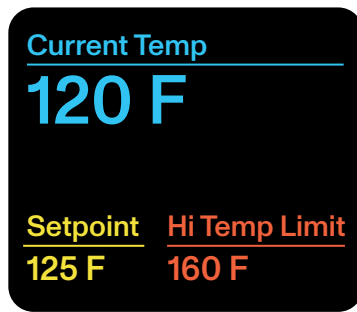

### Main Screen 1

On power up, the main screen is displayed.

Use to toggle between main screen views.

To enter settings, press and hold for 3 seconds.

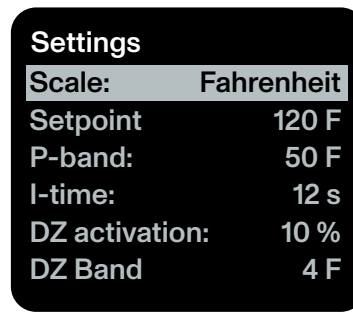

### Settings Screen

Use to toggle fields.

Press once to select.

Press and hold for 3 seconds to return to Main Screen.

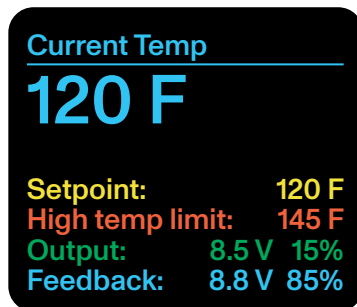

### Main Screen 2

Main Screen 2 shows more information.

**Output** is the percentage open of the hot port.

**Feedback** is the reading of the actuator position.

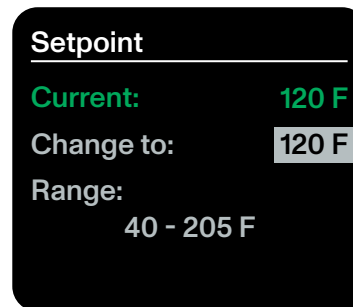

### Setting Adjustment Screen

Use to set parameter.

Press once to return to Settings.

---

## Settings Overview

- Scale** Changes the system units between Fahrenheit and Celsius.
- Set Point** The desired mixed outlet temperature, set in 1 degree Fahrenheit increments or 0.5 degree increments in Celsius. Adjustable from 40-205 F or 4.5 - 96.0 C. The system will work to maintain this target temperature at all times.
- P-Band and I-time** Both the Proportional Action “P-band” and Integration Time “I-time” are a function of the responsiveness and speed of the control loop signal change. The P band indicates the required change of control offset to cause a 100% output signal change. I.e., from 0 V to 10 V.
- Increasing the P-band decreases the speed of change of the control signal. For example, a P-band of 100 F has a 50% slower reaction than an P-band of 50 F.
- Decreasing the I-time will result in faster, but usually less responsive control.
- The default settings of P-band and I-time are default for a reason and should work for most domestic hot water mixing valve installations. Let the system run and stabilize before making changes to the P-band or I-time. A valve that is hunting is usually experiencing a system issue rather than the need for adjustment of the gain settings. See troubleshooting section of manual to rule out other issues before attempting to change the P and I settings.

---

## Settings Overview Continued

### **DZ Activation and DZ Band**

The dead zone activation “DZ Activation” and dead zone band “DZ Band” are unique features for the TC250D controller that prevent actuator wear and tear and can be used to maximize heater recovery in off peak hours.

The dead zone is eliminated as soon as the output crosses back into normal/high load conditions.

The DZ Activation point is expressed in percentage of control signal output. This is the threshold for the DZ Band. The factory default is 10%. At conditions of low load, when the valve is 10% or less open to the hot port, the leaving water temperature is allowed to drift 4 F (adjustable up to 12 F) (2C-6.5 C) below setpoint.

The dead zone can be eliminated all together if desired by switching the DZ Activation to OFF. This should be done in alternative applications where the load is consistent such as process heating and cooling.

### **Feedback Range**

The controller can read the feedback voltage on terminal 7 from an electronic actuator in 2-10VDC or 0-10VDC. This information is displayed through the main screen as well as the BMS communication.

The feedback is optional, has no impact on the controller output. If not connected, feedback will be displayed as 0%.

### **Output Range**

The controllers output can be changed from 0-10VDC to 2-10VDC for flexibility with alternative actuators.

### **Action**

The controller can be put in direct or reverse acting action.

This is useful for installations where it is desirable to reverse the hot and cold ports.

For direct action application 10 V will drive the stem down closing the B port.

For reverse action application 10 V will drive the stem up closing the A port.

When the hot water is piped to the B port, direct action should be used.

When hot water is piped to the A port, reverse action should be used.

### **Actuator Run Time**

The controllers output speed should be set to match that of the actuators run time.

Do not change this from 30 seconds when using the VM800 actuator.

Improperly changing this setting will result in reset wind up.

### **High Limit and High Limit Delay**

The high limit alarm is triggered when the leaving water temperature is higher than the alarm temperature setting and the delay time is passed. When this happens, the valve is closed to the hot port and the relay state changes. This is a manually reset alarm. The delay time is adjustable from 3 to 300 seconds.

For example if the high limit temperature is set for 145 F with a 20 second delay, if the leaving water temperature exceeds 145 F for 20 seconds, the alarm is triggered.

### **Modbus and BACnet**

These screens are used in conjunction with modbus and BACnet settings for BMS connectivity. See supplemental info for communication settings, registers and wiring.

### **Defaults**

Use this setting to restore the controller to factory default settings.

---

## How to Commission System

The TVS43 System does not require any special tools, software, passwords or knowledge to commission and program. The commissioning process can be done by the installing contractor, by completing the following steps.

Upon initial installation and wiring of the valve, the default settings should work. However, it is best practice to confirm that all of the desired functions work before finalizing the installation and turning over to ownership.

1. After installation, ensure that the heat source is on and the supply is sufficiently hot, at least a few degrees hotter than the setpoint of the mixing valve. Ensure that the return line circulator is running.
2. Close the hot port isolation valve and toggle DIP switch 9 on the actuator momentarily to start the calibration procedure. The valve should stroke up and down to its endpoints.
3. Leave the isolation valve on the hot supply closed and change the setpoint to 50 F. Watch to make sure the valve drives down closing the B port.
4. Raise the setpoint to 160 F (ensure the hot supply isolation valve is closed) and make sure the actuator drives up opening the B port.
5. **NOTE:** If the hot water enters on the A port, the opposite should happen.
6. Change the setpoint to the desired target and open all of the isolation valves. Allow the system to run and stabilize. The return line circulator should be running and the cold inlets to the mixing valve and hot water source should start to become warm. The return line may have to be purged of air.

---

### Setting Actuator to Automatic Mode

Flip green tab up towards you to put in automatic mode.

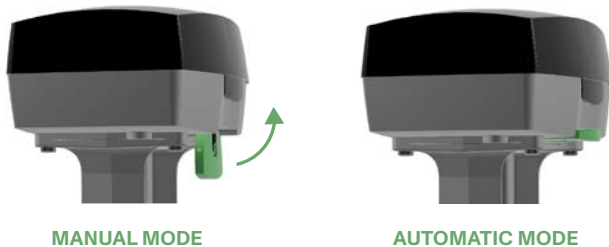

---

### Set Point Test

1. Leave all isolation valves open. Make sure the recirculation pump is running.
2. Adjust the set point to 50 F. The valve should drive down and close off the hot port.
3. Once the hot port is fully closed, watch the output leaving temperature. If this goes cold double check the return line circulator operation as well as the piping. When the recirculation is running, cold water entering should be warm. Anything less than 80 F is a sign the pump is not operational.
4. Often the pump motor will be running, but the volute is clogged or the impeller has become disconnected
5. Check for air in return line, especially after water shut down. It may have to be purged.

## Troubleshooting

ISSUE	CAUSE	RESOLUTION
No display	No power	<ul style="list-style-type: none"> <li>• Check to ensure there is 24VAC/DC +/- 10% on terminals 1 and 2.</li> <li>• Check to make sure the actuator has 24VAC/DC on terminals G and H.</li> <li>• Make sure to follow warnings and steps in regard to the ribbon cable connection. Avoid “hot plugging” - make sure power disconnected before removing or installing ribbon cable.</li> </ul>
No movement from actuator	Improper wiring  Actuator set to manual	<ul style="list-style-type: none"> <li>• Ensure that the wiring from the transformer that powers the actuator and control follows the correct polarity as shown in the wiring diagram.</li> <li>• The wire that powers G on the actuator must be common with 1 and the wire that powers H on the actuator must be common with 2.</li> <li>• Make sure the green tab on the face of the actuator is in the automatic mode position. If the tab is pointing down it is the manual mode.</li> <li>• Do not push the tab backwards, make sure the tab is pulled forwards. The microswitch under the cover needs to be made.</li> </ul>
Actuator drives wrong way	Action/DIP Switches set wrong	<ul style="list-style-type: none"> <li>• Hot entering on B port Action = direct</li> <li>• Hot entering on A Action = reverse</li> <li>• All DIP switches should be set to off. The port change should be done with the action of the controller, not the DIP switches.</li> </ul>
Lag in temperature / wrong temperature	Sensor not in water flow	<ul style="list-style-type: none"> <li>• Ensure the sensor is in the path of the water flow and not in a “dead leg”. Do not use excessive fittings. Longer sensors are available if required.</li> <li>• Do not use a thermowell unless instructed otherwise. The ST series sensors are not designed for use with thermowells.</li> </ul>
Valve Hunting	Return recirculation not flowing properly	<ul style="list-style-type: none"> <li>• Ensure that the return is piped in such a way that it goes back to the hot water source and the mixing valve, not just one or the other.</li> <li>• When the pump is running, the inlet to the heater and the cold port on the valve should be warm.</li> <li>• Check to make sure the return pump is on and working. Many times it is reported to us that the motor of the pump is running but the impeller has failed. May require pulling the pump to check internals.</li> <li>• Make sure all check valves are holding.</li> <li>• Make sure supply pressures are within 5 PSI of one another.</li> <li>• If there is a pressure boosting system on site, make sure the booster system is not short cycling, this can cause issues with the mixing valve performance.</li> <li>• Perform “setpoint test” on the page 9 to verify return pump operation.</li> </ul>

→ If you are experiencing issues call or text the factory at 718-650-5510. Texting pictures can be helpful.



The STI Series sensor is a 1.8kΩ is an immersion temperature sensor with integral stainless steel probe. They are available in two different immersion lengths and feature a ½" NPT connection. These are installed directly in the water flow, do not use a well.

The STI Series sensor is offered in two lengths.

### Technical Data

Max Water Pressure	250 PSI
Max Temperature	250° F
Characteristics	1.8 kΩ
Connection	1/2" NPT
Probe Length	STI-090 3.5" 90mm STI-130 5.5" 130mm
Rating	NEMA 4
Electrical Connection	2 wire quick connect terminal

### Physical Install

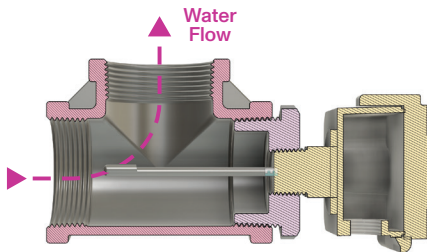

The STI series sensor has a ½" NPT connection and is to be installed directly into the water flow.

DO NOT use an additional thermowell unless one is specifically provided by the factory. The STI series sensors are not compatible with thermowells. The temperature measurement will be incorrect.

It is vital to mount the sensor in the water flow. ¾" to 2" systems feature a 3 ½" long probe sensor, 2 ½" and 3" feature a 5 ½" sensor. Mount the sensor in a tee or a heel tee in the outlet of the system piping.

### Wiring Diagram



Wires can be connected to either terminal. Polarity is not required.



# STEAM SPECIALTIES

## Float & Thermostatic Trap, Double Inlet/Double Outlet - Series 44 & 45

### APPLICATION

The MEPCO Series 44 & 45, Float & Thermostatic Trap with Double Inlet/Double Outlet configuration, is applicable to all types of steam heating systems and steam process equipment. These traps operate efficiently with pressures up to 15 lbs. for lower pressure applications and up to 125 PSI for higher pressure applications. Their purpose is to move air and water while preventing steam from entering the return piping.

These traps are manufactured in four sizes (3/4", 1", 1-1/4" & 1-1/2") for handling capacities of 300 to 4,300 lbs. of condensate per hour. Four (4) possible connections allow a greater flexibility in piping. These traps can be piped in and out from either side, for a total of four piping combinations depending on your particular needs. All working parts are made of non-corrosive metals especially adapted for this service, and each trap is individually tested for reliable operation.



Series 44 Float & Thermostatic Trap (Double Inlet/Double Outlet)

## FEATURES & BENEFITS

- 1. Simple, rugged construction.** This *MEPCO* trap consists of a body, cover and float valve assembly. Body and cover are cast iron; all working parts are made of non-corrosive metals especially adapted for this service.
- 2. Sensitive thermostatic action.** Charging the thermostatic disc under high vacuum assures sensitive and positive response to temperature and pressure over entire operating range. Disc corrugations are shaped to reduce hinge action at the rim of the disc and evenly distribute disc motion.
- 3. Instantaneous valve action.** Design of the float valve assembly permits rapid and positive valve action.

Location of the valve assures a deep water seal at all times.

- 4. Continuous rapid flow of water.** A lever operated discharge valve opens wide so that large volumes of water can flow continuously from trap.
- 5. Thorough testing.** In addition to tests made of the completed trap, each thermostatic disc is tested before it is assembled into the trap.
- 6. Minimum maintenance.** All working parts may be inspected, removed or repaired without disturbing piping connections. Clean-out plug at bottom of trap body permits easy flushing of dirt.

### PARTS/MATERIALS - 44 & 45 series traps

ITEM	PART	MATERIAL
1	Body	Class 30 Cast Iron
2	Cap	Class 30 Cast Iron
3	Disc (series 44)	Stainless Steel & Brass
3	Plug (series 45)	Brass
4	Hinge	Brass
5	Pin, hinge	Stainless Steel
6	Gasket	Non-asbestos Fiber
7	Seat	SST, Brass holder
8	Valve	Stainless Steel
9	Clip	Stainless Steel
10	Lever & Float Assy	Stainless Steel
11	Plug 1/4" NPT	Steel

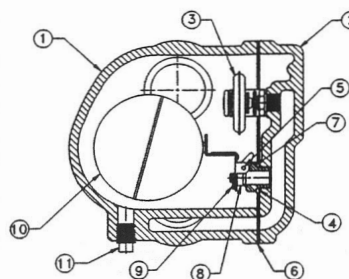

44 SERIES F&T TRAPS ASSEMBLY DRAWING

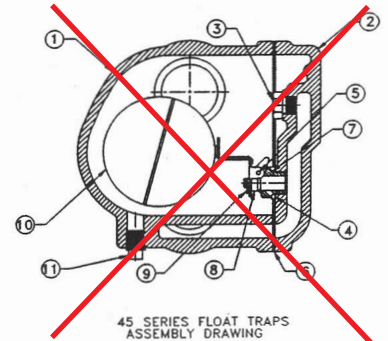

45 SERIES FLOAT TRAPS ASSEMBLY DRAWING

# Dimensions and Capacities

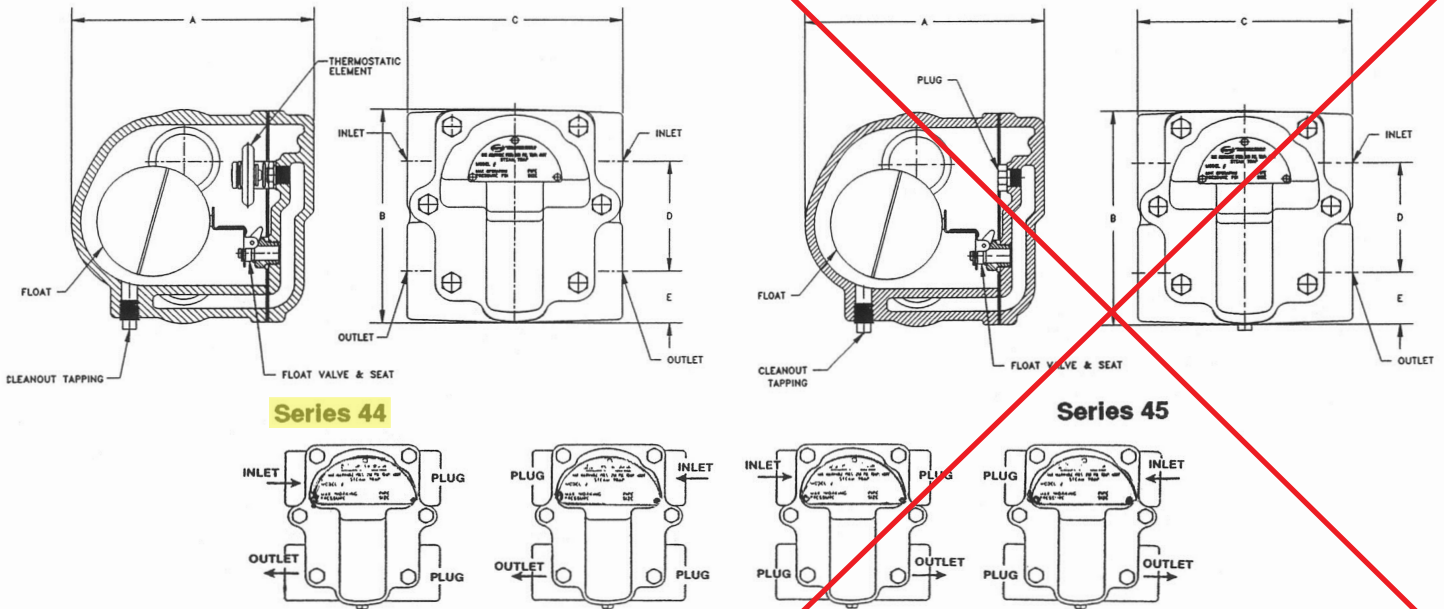

## Dimensions

TRAP NO.	TAPPING	A	B	C	D	E	F	G	NET WGT.(lb.)
44/45-2	3/4"	5-3/4	5-11/16	4-7/8	3-3/8	1-5/32	5-13/16	--	12
44/45-4	1"	5-3/4	5-11/16	4-7/8	3-3/8	1-5/32	5-13/16	-	12
44/45-5	1-1/4"	6-3/8	5-3/4	5-3/8	3	1-3/8	6-3/4	--	17
44/45-7	1-1/2"	6-3/8	5-3/4	5-3/8	3	1-3/8	6-3/4	--	17

## Capacities

	Model -215A			-230A			-275A			-2125A		
	No. -415A	-515A	-715A	-430A	-530A	-730A	-475A	-575A	-775A	-4125A	-5125A	-7125A
NPT Size	3/4"/1"	1-1/4"	1-1/2"	3/4"/1"	1-1/4"	1-1/2"	3/4"/1"	1-1/4"	1-1/2"	3/4"/1"	1-1/4"	1-1/2"
Orifice	.313	.344	.391	.250	.313	.391	.141	.188	.219	.109	.141	.172
1/4	600	750	980	425	600	800	300	375	400	275	300	350
1/2	825	1,000	1,365	600	825	1,100	375	500	525	310	375	450
1	1,000	1,200	1,855	750	1,000	1,450	425	600	675	350	425	550
2	1,225	1,400	2,410	900	1,225	1,800	500	710	825	390	525	650
5	1,575	1,900	3,150	1,250	1,575	2,400	625	935	1,075	450	625	800
10	1,875	2,300	3,750	1,500	1,875	2,900	725	1,050	1,250	500	725	950
15	2,175	2,700	4,075	1,725	2,175	3,400	825	1,225	1,425	540	825	1,050
20				1,900	2,500	3,750	900	1,375	1,575	600	900	1,150
25				2,050	2,750	4,050	975	1,525	1,725	660	975	1,275
30				2,300	3,000	4,300	1,000	1,675	1,850	725	1,100	1,400
40							1,200	1,825	2,000	850	1,200	1,500
50							1,350	1,950	2,200	1,000	1,350	1,625
60							1,500	2,100	2,400	1,100	1,500	1,780
75							1,650	2,400	2,700	1,280	1,650	1,950
90										1,410	1,825	2,100
100										1,500	1,900	2,275
125										1,650	2,100	2,500

Capacities given are continuous discharge in pounds of condensate per hour at pressure differential indicated, determined by tests conducted according to ASME Performance test Code 39.1-1980. Apply Safety Factor as required per application. Condensate within 5 degrees of steam temperature.



MARSHALL ENGINEERED PRODUCTS CO.



# SPECIALTIES

## Strainers, Cast Iron Type SS-A

### APPLICATION

The MEPCO Strainers are applicable to all types of steam and hot water heating systems. Their purpose is to protect traps, valves, heating elements, pumps, piping, etc. from dirt and scale which are often times the cause of a loss of heating efficiency.



STRAINER, Type SS-A

## FEATURES

### Cast Iron Strainer

- 1. Simple, rugged construction.** Strainer consists of a heavy iron casting with removable sieve and cover. Sieve is formed of perforated stainless steel sheet with .065 in. diameter holes, 100 per square inch. Special screens are furnished at slight extra cost. Strainer sieve cover is a cast iron bushing.
- 2. Easily cleaned.** Removable cover is located at bottom of strainer. Sieve is easily removed for cleaning.
- 3. Full range of sizes.** Strainer is manufactured in 1/2" thru 2" sizes. Strainer sieve cover is tapped for blow-off connection.
- 4. Operating Pressures.** For operating pressures up to 250 PSI for cast iron strainers.

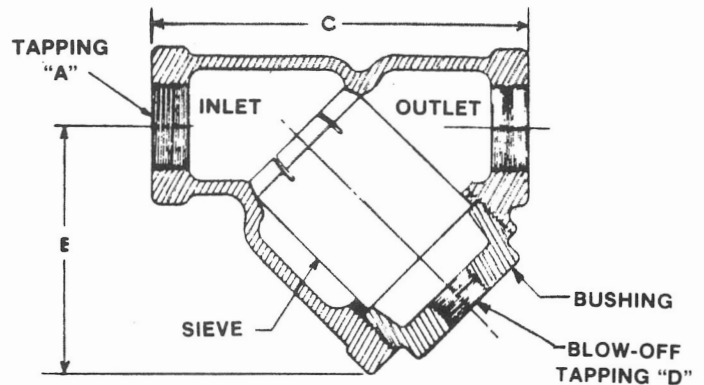

STRAINER Type SS-A

STRAINER TYPE	CONNECTION	SIZE "A"	DIMENSIONS					SHIPPING WEIGHT (LBS.)
			B	C	TAPPING D	E	OVERALL WIDTH	
SS-A	Screwed	1/2"	—	3-7/16"	3/8"	2-3/8"	2"	1-1/2
	Screwed	3/4"	—	4-1/2"	3/8"	2-1/2"	2"	1-3/4
	Screwed	1"	—	4-3/4"	1/2"	3-1/16"	2-7/16"	2-3/4
	Screwed	1-1/4"	—	5-1/4"	1/2"	3-1/4"	2-7/16"	3-1/2
	Screwed	1-1/2"	—	6-1/8"	1/2"	4"	3-5/16"	5-1/2
	Screwed	2"	—	6-1/8"	1/2"	4-1/4"	3-5/16"	7-1/2

WHEN ORDERING OR SPECIFYING, INDICATE: (1) Strainer Type, (2) Size



# VENT-RITE AIR VALVES PUT QUALITY ON THE LINE!



- Every Vent-Rite Valve is factory assembled, tested & inspected in the U.S.A.
- Each valve is individually packaged with external labeling for convenience and maintenance
- All brass internals with nickel plated and hand polished exterior.
- Adjustable vents have wide adjustment conveniently located below steam path



# Air Valves For Steam Systems

QUICK, UNIFORM DISTRIBUTION OF HEAT TO ALL RADIATION IS THE FIRST ESSENTIAL TO PERFECT PERFORMANCE. THIS REQUIRES BALANCING THE RADIATION BY CONTROLLED VENTING. VENT-RITE'S #1 NON-VACUUM VENTS ARE ADJUSTABLE AND ALL VENTS ARE DESIGNED FOR POSITIVE ACTION AND STRAIGHTLINE VENTING. THEY FUNCTION AUTOMATICALLY TO VENT THE AIR. IF, THROUGH AN UNUSUAL CONDITION, THE VENT IS FILLED WITH WATER, THE VENT PORT AUTOMATICALLY CLOSES.

VENT-RITE REPLACEMENT GUIDE		
VENT-RITE	DOLE	HOFFMAN
1 11	1A 1933	1A 40
31 33	3A 3B	41 43
35 75 77	4 3C 5	45 45 45
57	55	74

VENT-RITE NON-VACUUM VENTS						
USE FOR	NO.	CONNECTION	VENT PORT	OPER. PRES.	O.A. HT.	ADJ.
FREE STANDING RADIATORS	1	1/8" MALE	3/32"	3 PSI	3 1/4"	YES
	11		1/16"	6 PSI	2 3/4"	-
CONVECTOR AND RISERS	31	1/8" MALE	1/16"	6 PSI	3 3/4"	-
	33	1/4" MALE	1/16"	6 PSI	3 3/4"	-
MAIN VENTS	35	3/4" MALE X 1/2" FEMALE	3/32"	3 PSI	3 1/4"	-
	75		3/32"	5 PSI	4 5/8"	-
	77		1/8"	3 1/2 PSI	4 5/8"	-
UNIT HEATERS	57	3/4" MALE X 1/2" FEMALE	1/32"	20 PSI	4 5/8"	-
	NOTE:		#57 ALSO REDUCES DAMAGE CAUSED BY WATER HAMMER			

OPERATING PRESSURE (DROP AWAY) IS THE MAXIMUM PRESSURE AT WHICH THE VENT WILL CONTINUE TO OPEN AND CLOSE DUE TO THE CHANGE OF TEMPERATURE. THE VENT MAY BE USED WITH SLIGHTLY HIGHER PRESSURE PROVIDING IT DROPS BELOW THE OPERATING PRESSURE BETWEEN EACH FIRING CYCLE.

## For Commercial Water Heater Applications

# Series 40, 140, 240 & 340 Automatic Re-seating T&P Relief Valves

The combined 2-in-1 Temperature & Pressure Relief Valve provides the least expensive and proven means for protection against both excessive temperature and pressure emergency conditions.

Fully automatic temperature and pressure relief protection for domestic hot water supply tanks and heaters based on the latest ANSI Z21.22 Listing requirements for temperature discharge capacity.

40XL with test lever and extension thermostat for installation in hot water outlet within the allowable distance from the top of the tank based on latest ANSI Z21.22. Sizes 3/4" and 1" (20 – 25mm).

40L with test lever and short thermostat for installation directly in available tank tappings. Sizes 3/4" and 1" (20 – 25mm).

Series 140, N240 and 340 have the same basic body construction and advanced design features as the Series 40 and are identical to the Series 40 except for discharge capacity and size of inlet and outlet connections. For complete specifications (including specifications for the Series 40) see other side. Sizes 1", 1 1/4", 1 1/2" and 2" (25, 32, 40 and 50mm).

### Features

- Bronze body construction
- Non-mechanical seat-to-disc alignment
- Thermostat is accurate and proven. Exclusively designed and manufactured by Watts
- Tamper-resistant bonnet screws
- Series 40 and 140 feature a unique thermostat with a special thermo-bonded coating
- Series 140 sizes 1" (25mm) and above are standardly furnished with stainless steel thermostat tube

### Specifications

#### Temperature & Pressure Relief Valves

Each hot water storage heater shall be equipped with an automatic temperature and pressure relief valve to protect the heater from excessive pressure and excessive temperature. The device shall be certified as meeting the requirements of ASME low pressure heating boiler code and ANSI Z21.22. The BTU discharge capacity of the device shall be in excess of the BTU input rating of the heater. The T&P valve shall be a Watts Regulator Company Series 40, 140, 240 or 340.

### Standards



ASME Rated, ANSI Z21.22, Design certified and listed by CSA, National Board of B&PVI to Section IV of the ASME B&PV code and meet current FHA requirements and ANSI Z21.22 in addition to Military Spec. MIL-V-136-12D, Type I.

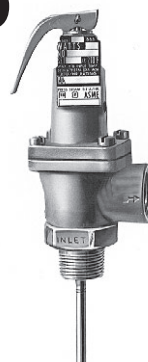

Series 40L and 40XL



Series 140X



Series N240X



Series 340

### Pressure – Temperature

Temperature relief 210°F (99°C)

Pressure range 75 – 150psi (5.2 – 10.3 bar)

Standard setting 75, 100, 125 and 150psi

(5.2, 6.9, 8.6 and 10.3 bar)

**Following installation, the valve lever MUST be operated AT LEAST ONCE A YEAR by the water heater owner to ensure that the waterways are clear.** Certain naturally occurring mineral deposits may adhere to the valve, blocking waterways, rendering it inoperative. When the lever is operated, Hot water will discharge if the waterways are clear. Precautions must be taken to avoid personal injury from contact with hot water and to avoid property damage.

**IMPORTANT: INQUIRE WITH GOVERNING AUTHORITIES FOR LOCAL INSTALLATION REQUIREMENTS**

## Direct Side Tapping

### FOR EXTERNAL FLUE HEATERS

Use extra length extension thermostat to extend into water storage tank.

### FOR INTERNAL FLUE HEATERS

Use short or standard length thermostat. Vertical discharge line must be installed with its direction downward.

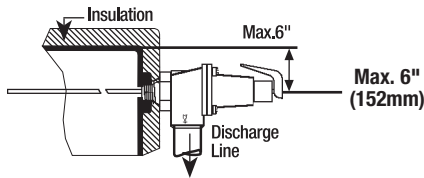

## For Heaters with Direct Top Tapping

Use standard or extra length extension thermostat.

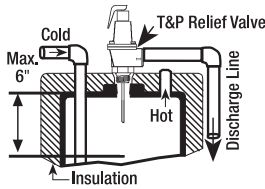

## General Recommendations†

For gas, electric or oil-fired storage water heaters between 180,000 to 205,000 BTU/Hr. rating: **Use ¾" (20mm) Series 40, 140 tested under ANSI Z21.22 with ratings as certified and listed by CSA.**

For gas or oil-fired storage water heaters between 205,000 and 730,000 BTU/Hr. rating and for compliance with applicable water heater labeling requirements: **Use 1" (25mm) 40, 140, N240 Series tested under ANSI Z21.22 with ratings as certified and listed by CSA.**

For installations of gas or oil-fired hot water supply boilers over 730,000 BTU/Hr. output heating domestic water and for steam coil storage water heaters: **Use Series 340, 342 tested under ANSI Z21.22 with rating as certified and listed by CSA.**

**SPECIAL MODEL:** No. 340X-8 M4Z 1½" (40mm) size only. Pressure setting 175psi (5.2 bar). Temp. 210°F (99°C). Certified by CSA only.

Model	Inlet X Outlet (in.)	Thermostat Length (in.) (Below Inlet thread)	Dimensions (in.)		Weight Lbs.	CSA Temp. Steam Rating BTU/HR	**ASME PRESSURE STEAM RATING BTU/HR			
			Height (Less Thermostat)	Width			@75psi set pres.	@100psi set pres.	@125psi set pres.	@150psi set pres.
40L-3	¾ M x ¾ F	3	5½	2½	1¾	180,000	777,600	997,600	1,217,600	1,437,600
40XL-5	¾ M x ¾ F	5	5½	2½	1¾	205,000	777,600	997,600	1,217,600	1,437,600
40XL-8	¾ M x ¾ F	8	5½	2½	1¾	205,000	777,600	997,600	1,217,600	1,437,600
140S-3	¾ F x ¾ F	3	5½	2½	1¾	180,000	777,600	997,600	1,217,600	1,437,600
140X-5	¾ F x ¾ F	5	5½	2½	1¾	205,000	777,600	997,600	1,217,600	1,437,600
140X-8	¾ F x ¾ F	8	5½	2½	1¾	205,000	777,600	997,600	1,217,600	1,437,600
40L-2	1M x 1F	2	6¼	2¾	2¼	450,000	1,155,000	1,481,000	1,808,000	2,134,000
40XL-4	1M x 1F	4	6¼	2¾	2¼	500,000	1,155,000	1,481,000	1,808,000	2,134,000
40XL-7	1M x 1F	7	6¼	2¾	2¼	500,000	1,155,000	1,481,000	1,808,000	2,134,000
*140S-3	1F x 1F	3	5½	3	2¼	570,000	1,670,000	2,140,000	2,610,000	3,085,000
*140X-6	1F x 1F	6	5½	3	2¼	670,000	1,670,000	2,140,000	2,610,000	3,085,000
*140X-9	1F x 1F	9	5½	3	2¼	670,000	1,670,000	2,140,000	2,610,000	3,085,000
*N240X-6	1F x 1F	6	6½	3¾	2¾	730,000	2,195,000	2,817,000	3,438,000	4,059,000
*N240X-9	1F x 1F	9	6½	3¾	2¾	730,000	2,195,000	2,817,000	3,438,000	4,059,000
*N241X-5	1¼ M x 1F	5	6½	3¾	2¾	730,000	2,195,000	2,817,000	3,438,000	4,059,000
*N241X-8	1¼ M x 1F	8	6½	3¾	2¾	730,000	2,195,000	2,817,000	3,438,000	4,059,000
*340-3	1½ F x 1½ F	3	9¾	4½	7	1,150,000	3,450,000	4,426,000	5,403,000	6,379,000
*340X-8	1½ F x 1½ F	8	9¾	4½	8	1,150,000	3,450,000	4,426,000	5,403,000	6,379,000
*342-3	2 M x 1½ F	3	9¾	4½	7	1,150,000	3,450,000	4,426,000	5,403,000	6,379,000
*342X-8	2 M x 1½ F	8	9¾	4½	8	1,150,000	3,450,000	4,426,000	5,403,000	6,379,000

\*Standardly furnished with stainless steel thermostat tube.

M = Male

F = Female

\*\*ASME capacities are steam pressure ratings and do not reflect the CSA temperature relieving capacity of the valves for selection purposes.

†LL40XL and LLL40XL valves with extended inlet shanks should be used for water heaters that have extra thick insulation, Ask for ES-LL/LLL-40XL.

**Temperature and Pressure Relief Valves should be inspected AT LEAST ONCE EVERY THREE YEARS**, and replaced, if necessary, by a licensed plumbing contractor or qualified service technician, to ensure that the product has not been affected by corrosive water conditions and to ensure that the valve and discharge line have not been altered or tampered with illegally. Certain naturally occurring conditions may corrode the valve or its components over time, rendering the valve inoperative. Such conditions can only be detected if the valve and its components are physically removed and inspected. Do not attempt to conduct an inspection on your own. Contact your plumbing contractor for a reinspection to assure continuing safety.



A Watts Water Technologies Company



USA: 815 Chestnut St., No. Andover, MA 01845-6098; www.watts.com

Canada: 5435 North Service Rd., Burlington, ONT. L7L 5H7; www.wattscanada.ca

# 2.5" Hot Water Thermometer with 1/2" NPT Connection

32-Degree (F) to 250-Degree (F)

## FEATURES

- **Dual scale** - Fahrenheit and Celsius readouts make this 50mm brass thermowell an economical and accurate way to measure air or water temperatures.
- **Easy to Install** - 1/2" NPT process connection makes the thermometer widely-compatible with equipment.

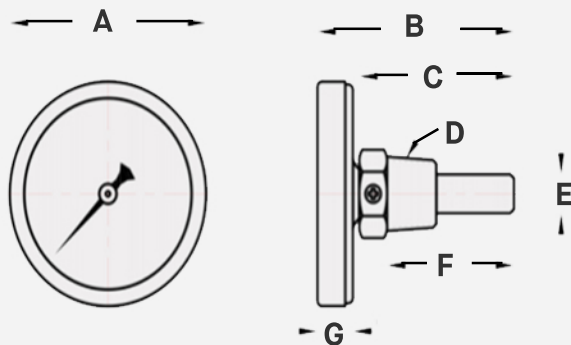
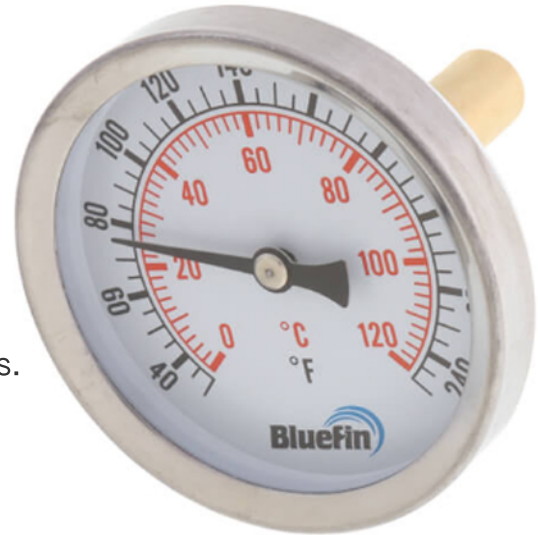

SKU	A	B	C	D	E	F	G
GTH25-50T	2.50"	2.50"	1.97"	1/2" NPT	0.43"	1.61"	0.45"

Temperature Scale	30-250°F / 0-120°C
Dial	2-1/2" black markings
Case	Chrome plated steel
Lens	Glass
Ring	Stainless Steel
Thermowell	Brass, 1/2" NPT, 50mm
Connection Type	Back
Stem	Brass
Pointer	Aluminum, painted black
Sensing Element	Bi-metallic element
Accuracy	2.5% of full scale